

FREE MANUAL * Do not pay for it*

16 PART MULTI TIMBRAL SYNTHESIZER

JV-30

OWNER'S MANUAL

please do visit the JV30 center



Roland



16 PART MULTI TIMBRAL SYNTHESIZER

JV-30

OWNER'S MANUAL

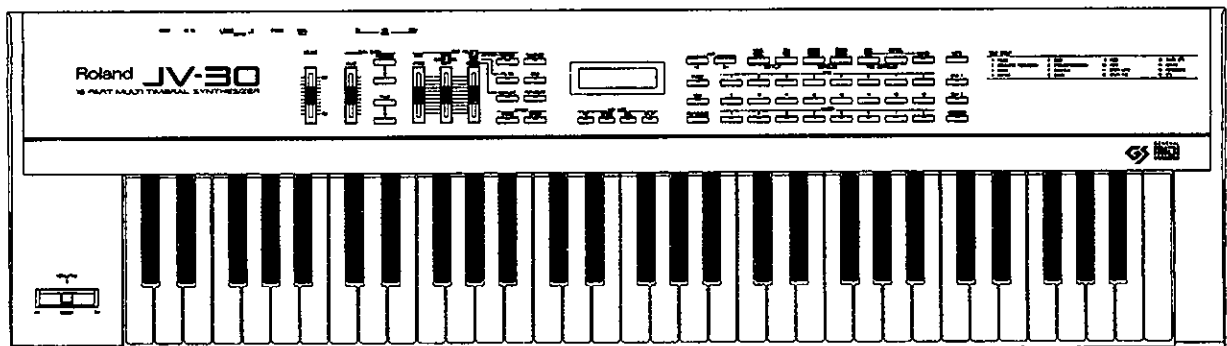

Roland

JV-30

16 PART MULTI TIMBRAL
SYNTHESIZER

OWNER'S MANUAL

INTRODUCTION

Thank you, and congratulations on your choice of the Roland JV-30 16 Part Multi Timbral Synthesizer.

Thanks to its high-quality, widely ranging selection of sounds, and easy-to-use, control features, it is sure to satisfy most everyone from beginner to seasoned professional. Moreover, it can easily be used to create ensemble effects, by making use of its multi timbral capabilities.

In order to gain an overall understanding of every feature this unit offers, and to ensure continued satisfaction for years to come, please take the time to read this manual in its entirety.



● General MIDI System

The General MIDI System is a set of recommendations which seek to provide a way for going beyond the limitations of proprietary designs, and standardize the MIDI capabilities provided by sound generating devices. If you use a sound generating unit which carries the General MIDI logo (), you will be able to faithfully reproduce any song data which also carries the General MIDI logo.



● GS Format

The GS Format is Roland's universal set of specifications which were formulated in the interest of standardizing the way in which sound generating devices will operate when MIDI is used for the performance of music. If you use a sound generating unit which carries the GS logo (), you will be able to faithfully reproduce any commercially available song data which also carries the GS logo.

This product supports both General MIDI and GS.

Song data which carries either of these logos can be accurately reproduced.

Copyright © 1992 ROLAND CORPORATION

All rights reserved. No part of this publication may be reproduced in any form without the written permission of ROLAND CORPORATION.

Features

● High-Quality Sounds

The JV-30 containing a wide variety of preset Tones and percussion sounds. From strikingly realistic acoustic sounds to the most contemporary lead synth Tones, the JV-30 delivers!

● Multi Timbral Function

The JV-30 is a 16 Part multi timbral synthesizer that is capable of taking full advantage of the capabilities of MIDI. When combined with a sequencer or computer it offers almost unlimited performance possibilities.

● GS Format Compatibility

The JV-30 is compatible with the GS format, a Tone-mapping standard developed by Roland. Any song data that has been created using a sound source that complies to the GS format can be performed identically on any other device with a GS format sound source.

● Easy Operation

Buttons and sliders have been designed to allow easy access to all sounds or functions. While enhancing the operational ease, they also allow easier control over all sound editing procedures.

● Four Key Modes

The JV-30 offers a total of four different key modes: Dual, Split, Fat, and Octave. A wealth of creative possibilities is now at your fingertips.

● Performance Button

The performance button can be used to obtain instantaneous changes in the JV-30's settings a convenient performance function.

● MIDI Controller Features

The unit is equipped with 3 sliders which act as MIDI controllers. They allow you to apply real-time expression to song data.

Conventions Used In This Manual

- Words or numbers enclosed with [] indicate panel buttons. For example, [PRESET] refers to the Preset button, whereas BANK [1] indicates the button for Bank No. 1.

- Whenever arrow symbols appear, such as PART [◀] [▶], or PARAMETER [▲] [▼], it means that you should press one or the other of such buttons; whichever is appropriate in the particular case.

Important Notes

Be sure to use only the adaptor supplied with the unit. Use of any other power adaptor could result in damage, malfunction, or electric shock.

[Power Supply]

- When making any connections with other devices, always turn off the power to all equipment first; this will help prevent damage or malfunction.
- Do not use this unit on the same power circuit with any device that will generate line noise, such as a motor or variable lighting system.
- The power supply required for this unit is shown on its nameplate. Ensure that the line voltage of your installation meets this requirement.
- Avoid damaging the power cord; do not step on it, place heavy objects on it etc.
- When disconnecting the AC adaptor from the outlet, grasp the plug itself; never pull on the cord.
- If the unit is to remain unused for a long period of time, unplug the power cord.

[Placement]

- Do not subject the unit to temperature extremes (e.g. direct sunlight in an enclosed vehicle). Avoid using or storing the unit in dusty or humid areas or areas that are subject to high vibration levels.
- Using the unit near power amplifiers (or other equipment containing large transformers) may induce hum.
- This unit may interfere with radio and television reception. Do not use this unit in the vicinity of such receivers.

[Maintenance]

- For everyday cleaning wipe the unit with a soft, dry cloth (or one that has been slightly dampened with water). To remove stubborn dirt, use a mild neutral detergent. Afterwards, be sure to wipe the unit thoroughly with a soft, dry cloth.
- Never use benzine, thinners, alcohol or solvents of any kind, to avoid the risk of discoloration and/or deformation.

[Additional Precautions]

- Protect the unit from strong impact.
- Do not allow objects or liquids of any kind to penetrate the unit. In the event of such an occurrence, discontinue use immediately. Contact qualified service personnel as soon as possible.
- Never strike or apply strong pressure to the display.
- Should a malfunction occur (or if you suspect there is a problem) discontinue use immediately. Contact qualified service personnel as soon as possible.
- A small amount of noise may be heard from the display, and thus should be considered normal.
- To prevent the risk of electric shock, do not open the unit or its AC adaptor.

[Memory Backup]

- The unit contains a battery which maintains the contents of memory while the main power is off. The expected life of this battery is 5 years or more. However, to avoid the unexpected loss of memory data, it is strongly recommended that you change the battery every 5 years.
- When the battery becomes weak, the following message will appear in the display: "Battery Low!". Please change battery as soon as possible to avoid the loss of memory data.
- Please be aware that the contents of memory may at times be lost; when the unit is sent for repairs or when by some chance a malfunction has occurred. Important data should be stored in another MIDI device (e.g. a sequencer), or written down on paper. During repairs, due care is taken to avoid the loss of data. However, in certain cases, (such as when circuitry related to memory itself is out of order) we regret that it may be impossible to restore the data.

CONTENTS

Panel Descriptions	6
Making the Connections	8
Turning the Power On	9
Listening to the Demo Songs (ROM Play)	10

Section I PLAYING

Auditioning the Sounds	12
Playing Drum Sets	14
Changing Parts	15
Selecting the Key Mode	16
Using/Making Settings for the Performance Features	18
Setting Performance Functions Applying to All Parts	20
Setting Performance Functions for Individual Parts	22
Editing Tones	24
Storing Edited Tones	25
Editing Drum Sets	26
Storing Edited Drum Sets	27
Performances	28

Section II USING MIDI

Using MIDI 1	30
Using MIDI 2	32
MIDI Settings	34
Making Full Use of the Multi Timbral Features	36
MIDI Controller Features	38
Restoring the Original Settings	39
Obtaining MT - 32 Sound Ordering	39
Saving the JV - 30's Data	40

Section III APPENDIX

Concerning GS, General MIDI System	44
Troubleshooting	45
Error Messages	46
Transmitted MIDI Messages	47
Organization of Sounds in the JV - 30	48
JV - 30 Program Numbers	49
Parameter List	50
Tone Table	52
Drum Set Table	56
Roland Exclusive Messages	59
MIDI IMPLEMENTATION	61
TOPICAL INDEX	74
INDEX	76
SPECIFICATIONS	78

Panel Descriptions

<FRONT PANEL>

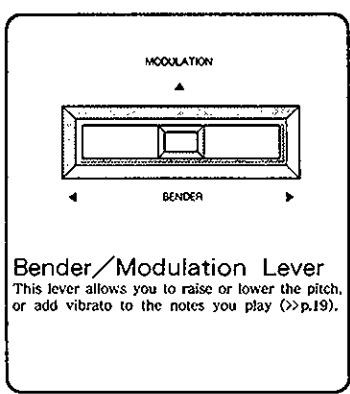
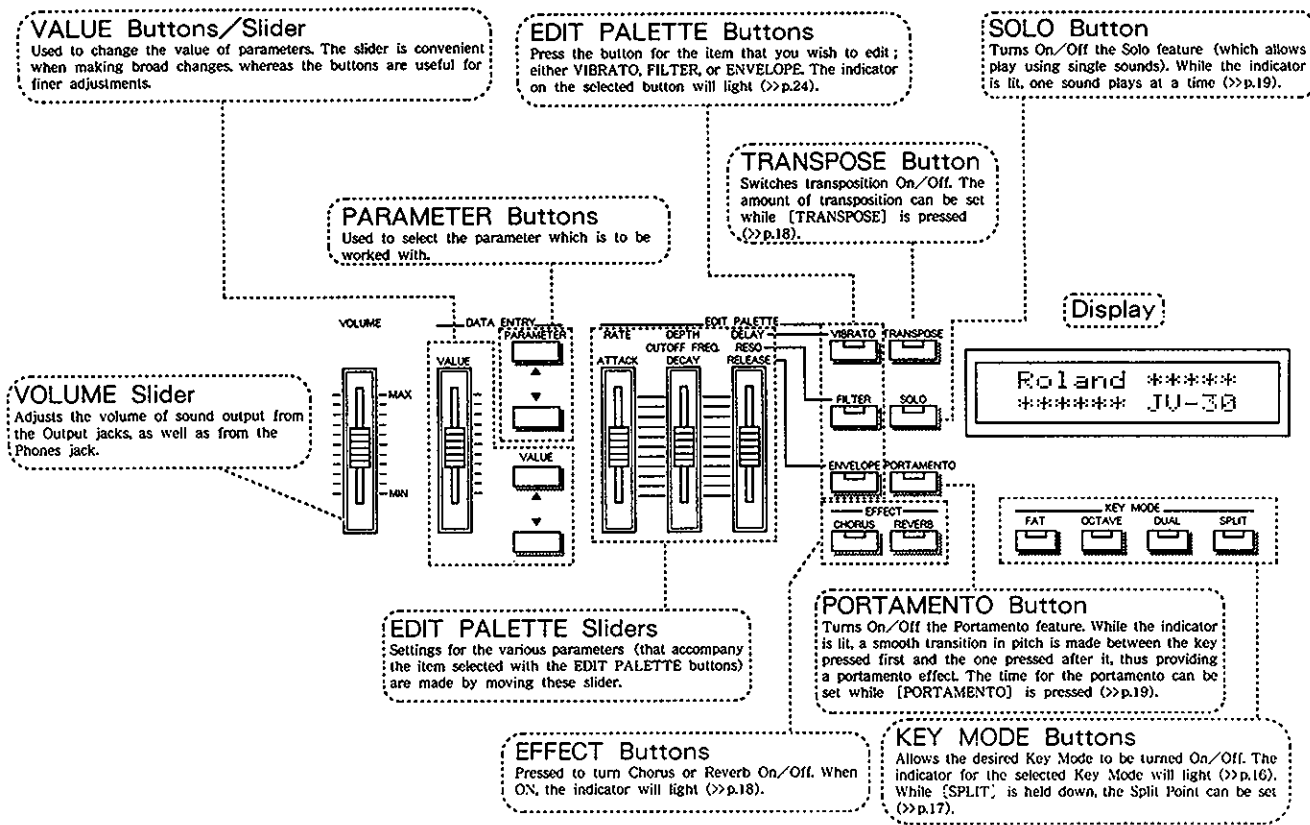

<REAR PANEL>

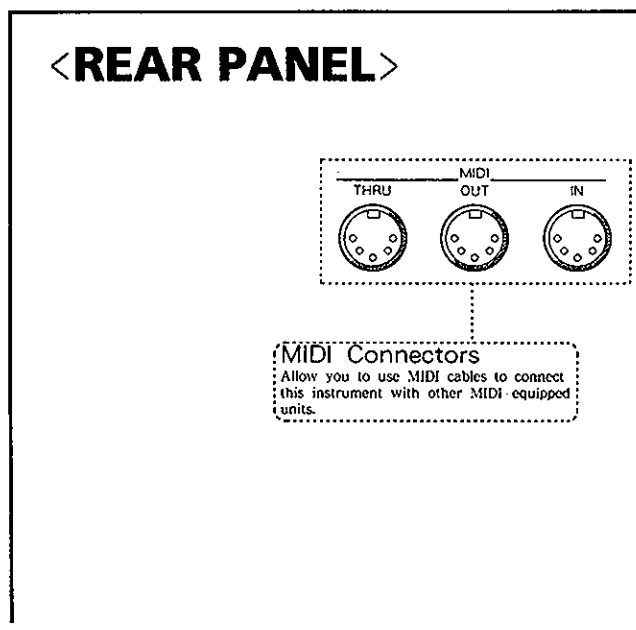

PART Buttons
 Pressed to switch among Parts (>> p.15).

TUNE/PAN Button
 Pressed to adjust the overall tuning for the unit (>>p.20), and to adjust the pan setting for each Part (>>p.22).

REVERB Button
 Used to set the overall Reverb Level and Type (>>p.21), as well as to set the Reverb Send Depth for each Part (>>p.23).

CONTROL Button
 Used to make settings for a variety of parameters for each Part (>>p.24).

LEVEL Button
 Pressed to adjust the volume of the unit as a whole (>>p.20), as well as that of each Part (>>p.22).

CHORUS Button
 Used to set the overall Chorus Level and Type (>>p.21), as well as to set the Chorus Send Depth for each Part (>>p.22).

MIDI Button
 Used to set the MIDI parameters: both those having an overall effect (>>p.34), and those for each Part (>>p.35).

MASTER Button
 Pressed when wishing to make settings for the unit's overall functions (indicated in blue). Settings for such functions can be made when the indicator is lit.

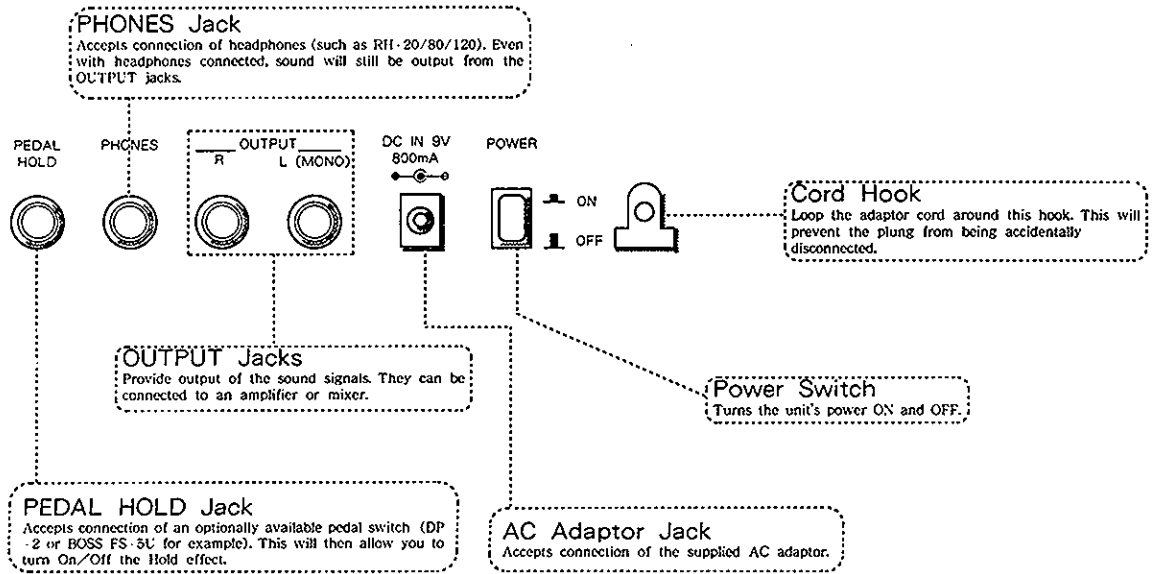
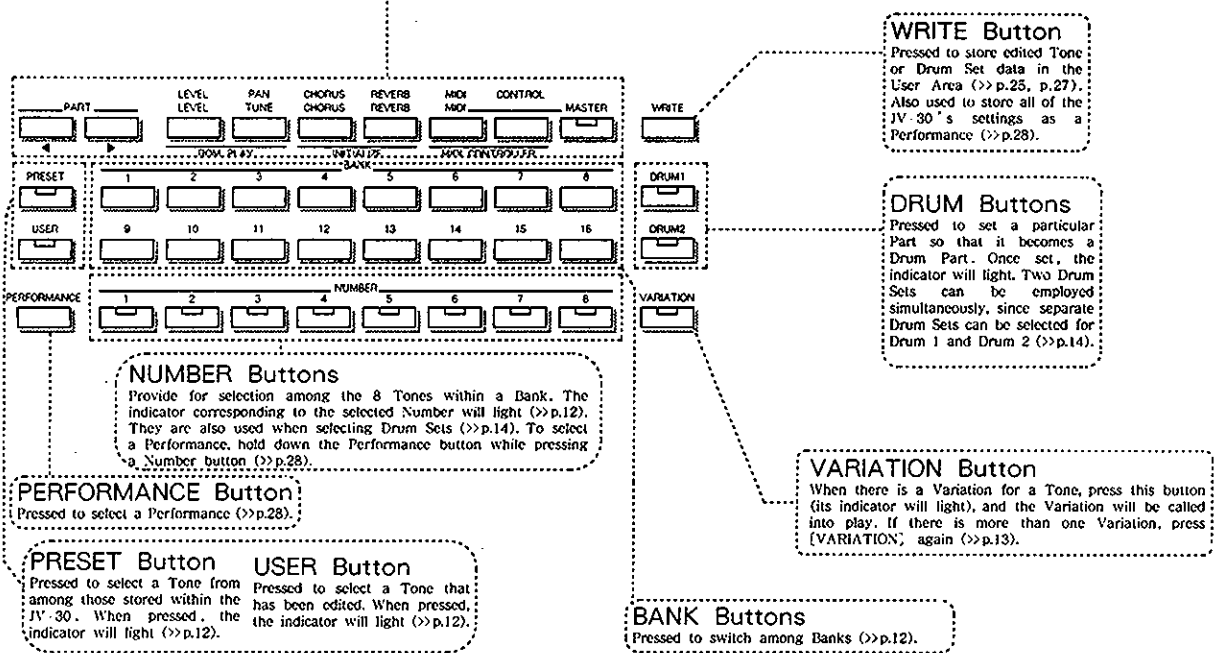

Making the Connections

Before connecting any cords, make sure you have the power switch turned OFF on this unit, as well as on any other equipment, such as an amplifier or mixer. Additionally, make sure to have the volume on your amplifier or mixer is set at the lowest possible level. This way, you can prevent damage to speakers or other equipment during the power up procedure.

Following the illustration below, connect the JV-30 with your external devices.

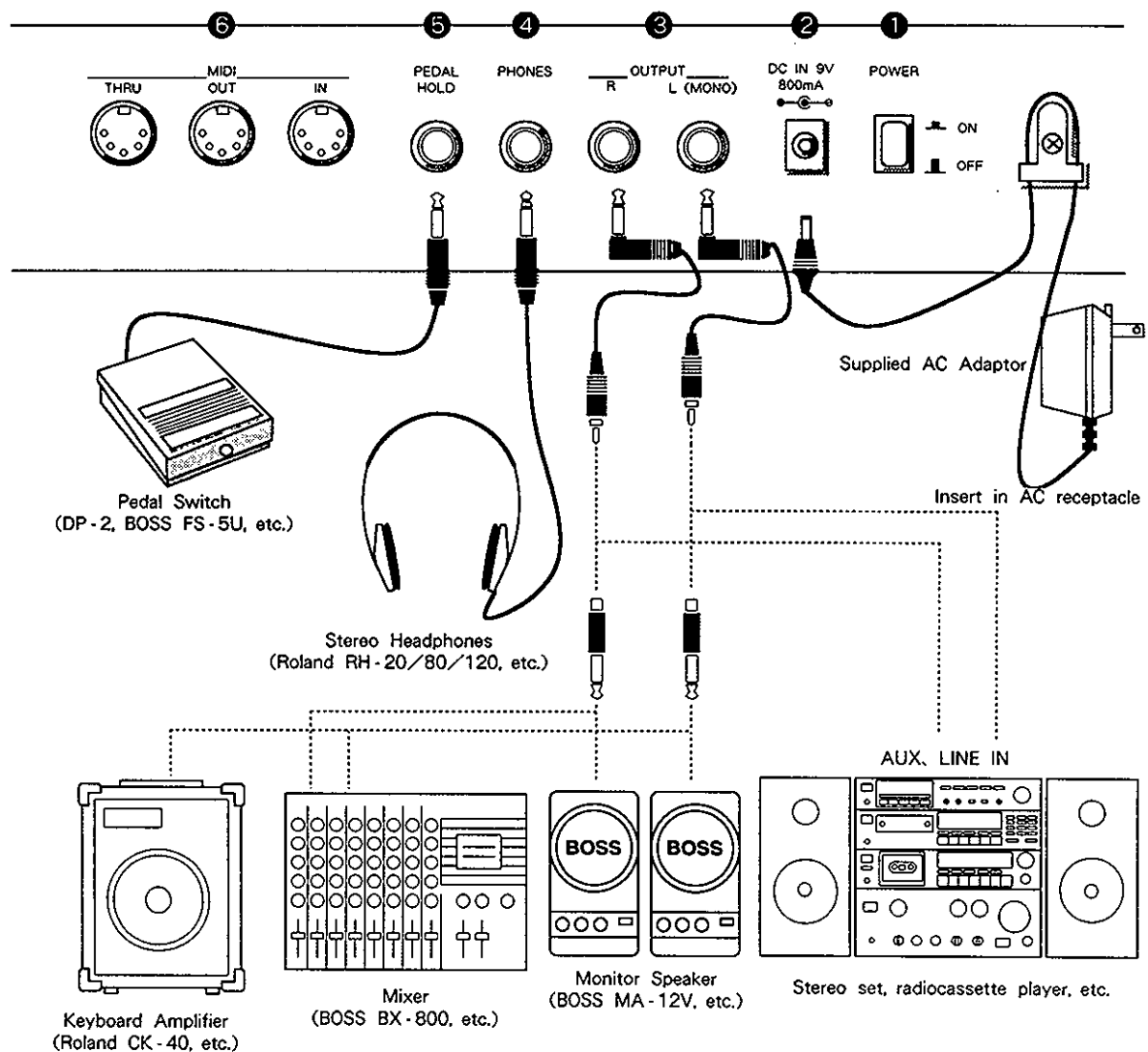

* Pedal switches, MIDI cables, and stereo headphones are all optionally available items.

* Please use only Roland or BOSS pedal switches. The unit may not operate as expected if you substitute products from a different manufacturer.

1 Power Switch

Push to turn the unit's power ON or OFF.



2 AC Adaptor Jack

Use only the supplied AC adaptor. The AC adaptor should be looped around the hook located to the right of the Power Switch. This prevents the cord from being accidentally pulled out while you are playing.

3 OUTPUT Jacks

Provide output of the sound signals. They can be connected to an amplifier or mixer, or some other unit. In order to get the most out of this instrument, the use of stereo output is recommended. If you wish to play in monaural, use only the L (MONO) jack.

When connecting to a home stereo or similar system, remove the adaptor plug from the supplied cable.

4 PHONES Jack

Stereo headphones should be used.
Headphones: RH-20, RH-80, RH-120 etc.

5 PEDAL HOLD Jack

Accepts connection of a pedal switch. While the pedal is depressed, decaying-type sounds (such as the piano), will decay more slowly. Sounds which normally tend to be sustained will sound continually.

6 MIDI Connectors

Allow you to use MIDI cables to connect this instrument with other MIDI-equipped units. For details, refer to "Using MIDI 1" (» p.30).

Turning the Power On

Once all connections have been completed, turn on the devices in the following order:

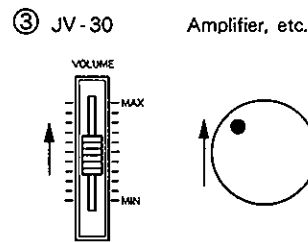
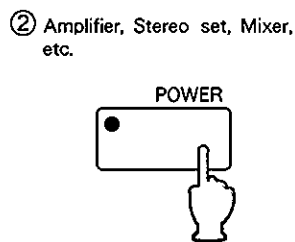
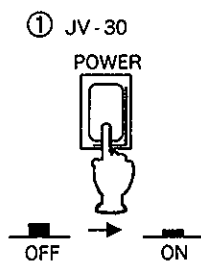

- ① Turn on the JV-30.
- ② Turn on the power to the mixer and/or amplifier.
- ③ Set the volume control on each unit at an appropriate level.

- * This instrument requires a few seconds immediately after the power is turned on before it is ready for operation. This is due to its circuitry protection feature.
- * Power down your system in the reverse order (ie., the JV-30 last).

When turn the power on, you'll see the following screen:

```
Roland *****
***** JV-30
```

After a few seconds it'll change to this:

```
1 Piano 1
P: 1-1
```

displaying the currently selected Tone.

Listening to the Demo Songs (ROM Play)

The JV-30 contains two demonstration songs stored in ROM which take full advantage of the instrument's multi timbral sound generation capabilities. To hear the Demo Songs, follow this procedure:

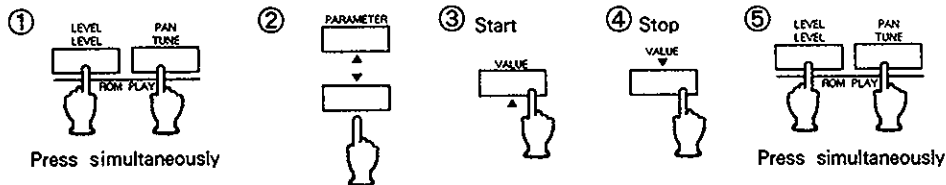

- ① Press [LEVEL] and [PAN] simultaneously. The following will appear in the display:

```

  *** ROM PLAY ***
  All Songs
  
```

- ② Press either the PARAMETER [▲] or [▼] key to select a song.
If you do not make this selection, the unit will play both songs, one after the other.
- ③ Press VALUE [▲] to start song play.
- ④ Press VALUE [▼] to stop song play.
- ⑤ To exit the ROM Play mode, you must once again simultaneously press [LEVEL] and [PAN].
The display will show what it did before entering the ROM Play mode.

- * The keyboard cannot be used to play anything while ROM Play is in progress.
- * The performance data for these demonstration songs is not output from MIDI OUT.

Song Title	Biographies of Composers
Dreamscape Music by Adrian Scott Copyright © 1991, Adrian Scott	Adrian Scott Adrian Scott formerly handled the vocals and keyboards for the popular group from Australia, "Air Supply". Since following the solo path, he in 1984 won the Silver Prize at the "World Song Festival Tokyo '84". Currently, he is involved as a producer of commercial music and music for films. In addition, as a session player, he has performed along with a number of Australia's top musicians, including John Farnham and Kylie Minogue. He lives in Melbourne, Australia.
ROUND AND ROUND Music by Chong Lim Copyright © 1991, BMG Publishing	Chong Lim Chong Lim is a busy session keyboard player, arranger, producer and composer working mainly in the cities of Melbourne and Sydney, Australia. He has collaborated with many top international artists including Jermaine Jackson, Jenny Morris, Little River Band, The Eurogliders etc. He is also actively involved in the composition of soundtrack music for film and television.

- * Please note that relevant laws prohibit the recording of the demonstration songs on tape, as well as their use for public performance or broadcast (and all other usage which would extend beyond private, personal enjoyment) without the permission of the holder of the rights to such material.

Section I

PLAYING

Auditioning the Sounds

Contained within the JV-30 is a comprehensive selection of Tones. Follow the instructions below to select those you are interested in and hear how they sound.

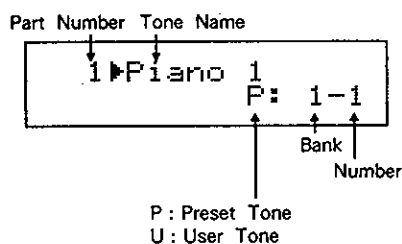

● Preset Tones

This Tone Group contains all the Tones that were stored in the unit when it was manufactured. The Preset Tones are organized into 16 Banks, each having 8 Numbers. The Bank Name is displayed on the upper right of the front panel, so that you'll know what of Tone is in a particular Bank. These 128 Tones, which can be selected using BANK buttons [1]-[16] and NUMBER buttons [1]-[8], are referred to as "Capital Tones."

● User Tones

This Tone Group contains all the Tones that have been altered to your liking. Any Tone that you have made changes to, whether it was originally a Preset or a User Tone, can be saved as a User Tone that is identified by means of BANK/NUMBER system.

[Selecting Tones]

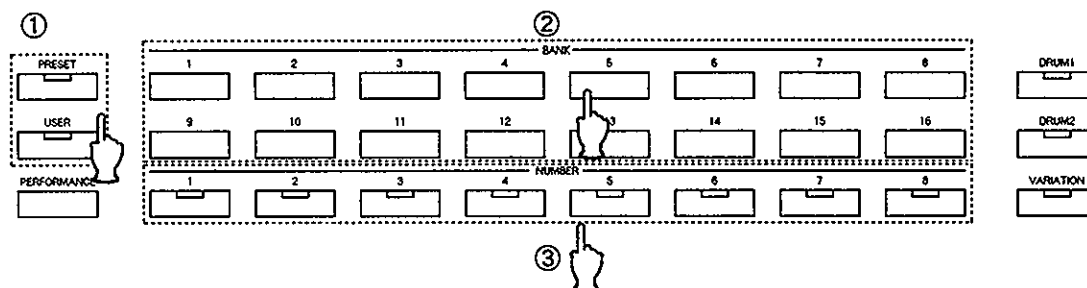

- ① Press [PRESET] to select a Preset Tone.
 To select a User Tone, press [USER].
 Selections can be made from the Tone Group where the indicator is lit.
 - ② Using BANK [1]-[16], select the Bank.
 - ③ Using NUMBER [1]-[8], select the desired Number.
 The indicator on the button which has been pressed will be lit.
 Now, play the keyboard, and it will sound using the selected Tone.
- * Any button, whether it be [PRESET]/[USER], [BANK] or [NUMBER], will result in an immediate change to a new Tone if pressed.
 * Try playing as many of the sounds as you wish, while referring to the "Tone Table" (» p.52).

● **Variation**

Certain Preset Tones provide related Tones containing a different nuance. These are referred to as "Variation." Note that while some Tones may have a number of Variations, others will have none at all.

*** User Tones have no Variation.**

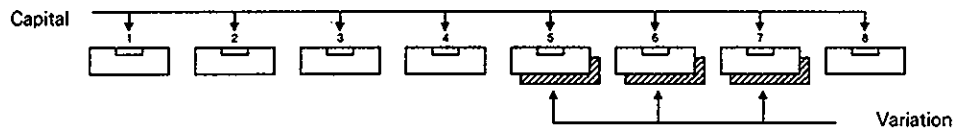

[Selecting Variations]

Whenever you have a Tone selected that provides a Variation, press [VARIATION] to select the Variation. With Tones carrying a number of Variations, each additional press of [VARIATION] allows you to select the next in the series of available Variations.

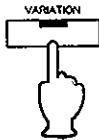

After all Variations have been called up, the indicator light will go out and the Capital Tone will return. Or, the Capital Tones will also return if you press [BANK] or [NUMBER].

*** Should you press [VARIATION] when the Tone has no Variation, the sound simply remains the same.**

Playing Drum Sets

The JV-30 contains a number of Drum Sets which allow a wide range of percussion instruments to be played, with a different sound produced by each key on the instrument. Similar to ordinary Tones, there are Preset Drum Sets which are stored in the instrument, as well as User Drum Sets which can be edited to your liking (before being stored).

Follow the instructions to play percussion sounds within the various Drum Sets.

There are 9 Drum Sets and they correspond to the buttons as shown below:

Button	Drum set name
NUMBER 1	STANDARD Set
NUMBER 2	ROOM Set
NUMBER 3	POWER Set
NUMBER 4	ELECTRONIC Set
NUMBER 5	TR-808 Set
NUMBER 6	JAZZ Set
NUMBER 7	BRUSH Set
NUMBER 8	ORCHESTRA Set
VARIATION	SFX Set

✦ For information on which instruments are assigned to which keys, refer to the "Drum Set Table" (» p.56).

[Selecting Drum Sets]

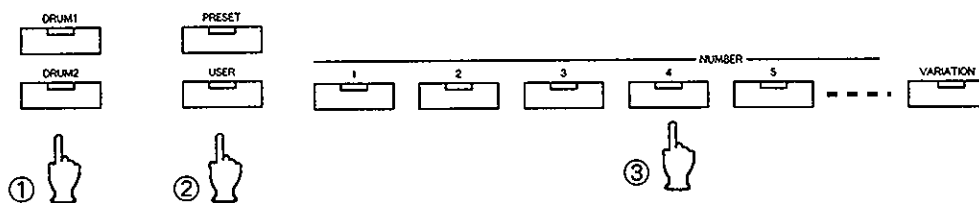

- ① Press either [DRUM1] or [DRUM2].
The indicator on the button you have pressed will light.
 - ② To select a Preset Drum Set, press [PRESET].
To select a User Drum Set, press [USER].
 - ③ Press NUMBER [1]-[8] or [VARIATION].
The indicator on the button pressed will light. The percussion sounds of that Drum Set can now be played on the keyboard.
- * To return to an ordinary Tone after using a Drum Set, press BANK [1]-[16], then re-select a Tone.
- * When you wish to play a percussive sound that uses a note lying beyond the range of the keyboard, use the Transpose function to shift the keyboard's playing range (» p.18).

Changing Parts

The JV-30 is capable of playing 16 Parts. Parts can be likened to separate performers, each playing on a particular instrument. A different Tone can be assigned to each of the Parts. An ensemble effect can be obtained by having a number of Parts play together, but in order to do this, you will need to have a sequencer or similar device.

However, the JV-30 alone can be used creatively as explained below.

- You could assign the Tones (that you need for a series of songs, for example) to Parts in numerical order. Then while playing, instantaneously switch to the needed Tone simply by changing to the next Part.
- When switching among Parts, a Variation of a Tone that has been assigned to a Part does not revert to the Capital Tone. This is convenient, since, for example, if you have a Tone Variation assigned to Part 1, that sound will be ready and playable whenever you choose Part 1, even after switching to other Parts for a while. In other words, by using Parts, you can more quickly select Variations.

[Selecting Parts]

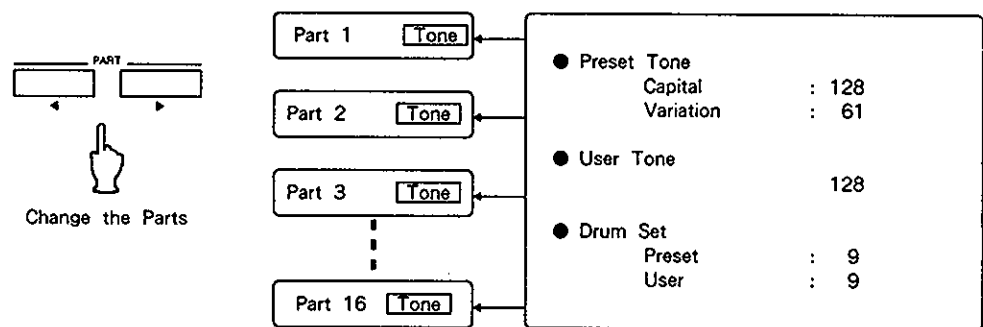

To change Parts, use PART [◀] [▶].

A different Tone or Drum Set can be assigned to each of the Parts. Change the Part using PART [◀] [▶], and assign a Tone or a Drum Set to each of the Parts. For information on how to select a Tone or Drum Set, refer to "Selecting Tones (» p.12)" or "Selecting Drum Sets (»p.14)".

* When assigning Drum Sets, take note of the following:

Although any Part can have a Drum Set assigned to it, only two Drum Sets can be handled at one time, one for Drum 1 and one for Drum 2.

For example, if the Parts are assigned Drum Sets as shown below, and you then change the Drum Set for Part 1 to ROOM Set, the Drum Set for Part 3 will also change to ROOM Set.

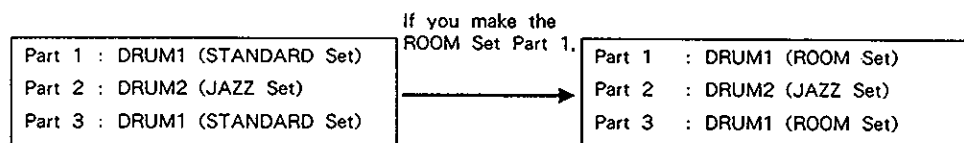

Selecting the Key Mode

The JV-30 provides the following 4 Key Modes, allowing you to alter the type of expression applied to a Tone, or to play two Tones layered together.

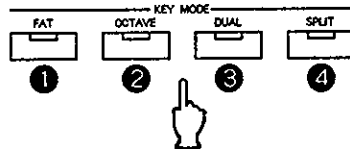

① FAT

Adds sound portions which have been minutely shifted in pitch to the currently selected Tone. This makes the Tone fatter or fuller. When output in stereo, the sound will be broader, spanning the stereo spectrum from left to right.

② OCTAVE

Adds sound portions which are one octave lower in pitch to the currently selected Tone, making it fatter.

③ DUAL

Layers another Tone with the currently selected Tone. A great range of sound creations are possible, depending on the choices made for this combination of sounds.

[Changing Tones]

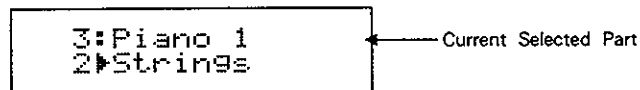

- ① Move the cursor (▄) using PARAMETER [▲] [▼], and select the Part for which you wish to change the Tone.

The Tone can be changed for the Part where the cursor appears.

- ② Use the Tone Selection button to change the Tone.

* Using PART [◀] [▶], the Part where the cursor appears can be changed.

4 SPLIT

Allows the keyboard to be split into two zones, at a specified point (Split Point). This makes it possible for you to play a different Tone in each zone. The currently selected Tone will be assigned to the zone located above the Split Point, while the newly selected second Tone will play in the zone below it.

The Split Point can be set anywhere within the range C2-C#7.

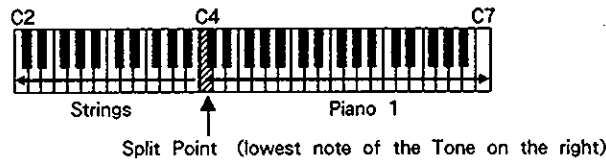

[Changing Tones]

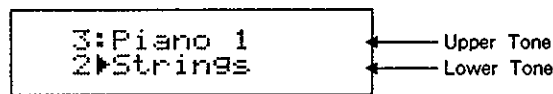

- 1 Move the cursor (⌂) using PARAMETER [▲] [▼], and select the Part for which you wish to change the Tone.
The Tone can be changed for the Part where the cursor appears.

- 2 Use the Tone Selection button to change the Tone.

* Using PART [◀] [▶], the Part where the cursor appears can be changed.

[Setting the Split Point]

- 1 Press [SPLIT] to view the current setting for the Split Point.

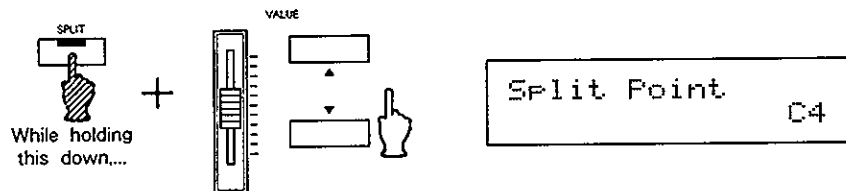

- 2 Hold down [SPLIT], and use either the VALUE slider or VALUE [▲] [▼] to set the Split Point.

- 3 Release your finger from [SPLIT], and the new Split Point is stored in memory.

* All of the Key Modes employ two Parts when sound is produced. With Fat and Octave, the Part which immediately precedes the currently selected one is employed. For example, if Part 2 is currently selected, and you then choose Fat or Octave as the Key Mode, Part 1 will be combined into the resulting sound. If Part 1 was originally selected, Part 16 will be the one added.

For example, when using the sequencer for ensemble play, if you use Fat/Octave on Part 2, then Part 1 notes won't sound.

With Dual and Split, the two Parts shown in the display are used. You should be careful with the allocation of Parts when employing a sequencer if a Key Mode is in effect.

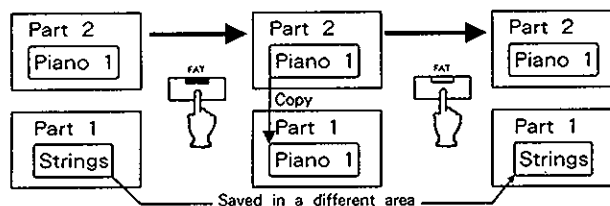

Using/Making Settings for the Performance Features

The following provides instruction on how to take advantage of a number of functions which enhance the performance capabilities of the instrument.

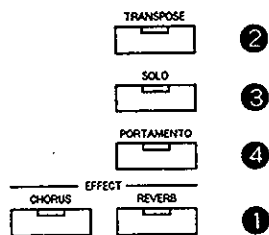

① Effects

The JV-30 is equipped with two effectors, which provide Chorus and Reverb.

● Chorus

Adds greater spaciousness and fatness to the sound. It is most effective when applied to organ or string Tones.

● Reverb

Applies an effect to the sound which makes it seem as if it were being played in a concert hall.

To turn Chorus ON, press [CHORUS]. Confirm that the indicator is lit.

To turn Reverb ON, press [REVERB]. Confirm that the indicator is lit.

Press the relevant button again to turn the effect off.

* If you wish to change the Chorus or Reverb type, or the manner in which it is to be applied, refer to "Setting Performance Functions Applying to All Parts" (» p.20).

② Transpose

This function allows the keyboard's playable range to be shifted in semitone units. Transpose is convenient for accommodating the pitch of a singer's voice, for making songs in difficult keys easier to play, and for accessing percussive sounds that normally are beyond the keyboard's range.

To turn Transpose ON, press [TRANSCOPE]. Confirm that the indicator is lit.

Press [TRANSCOPE] again to turn the function OFF.

[Setting the Amount of Transposition]

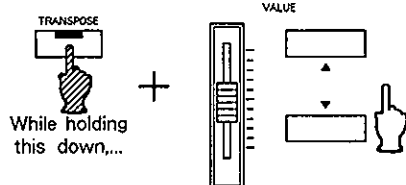

- ① Hold down [TRANSCOPE], and use either the VALUE slider or VALUE [▲] [▼] to set the amount by which the Pitch is to be shifted.

The amount of transposition is set in semitones, within a possible range of ± 2 octaves (-24 to $+24$).

Transpose -12

- ② Release your finger from [TRANSCOPE], and the amount of transposition is stored in memory.

Since the unit stores the setting, the range will be transposed by the same amount each time you turn on the Transpose function.

* if a setting of "0" has been made for the amount of transposition, the indicator on the button will not light when pressed.

Using/Making Settings for the Performance Features

3 Solo

This feature allows you to specify that only one sound is to be played. This can be used whenever you wish to have only one sound used at a time, such as for solo pieces, or brass type sounds.

Press [SOLO], and confirm that its indicator is lit. The instrument will now only play one sound. Press [SOLO] again to turn the function OFF.

* If a Drum Set is currently selected, [SOLO] will have no effect if pressed.

4 Portamento

Portamento is an effect which provides a smooth transition in pitch between the key pressed first and the key pressed after it.

Press [PORTAMENTO], and confirm that the indicator is lit. Portamento will now be in effect. Press [PORTAMENTO] again to turn the function OFF.

* When you press [PORTAMENTO], and the indicator on its button lights, the indicator on [SOLO] automatically lights, allowing the instrument to be played using one sound.

[Setting the Portamento Time]

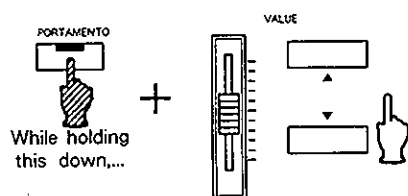

Perform the steps below to set the amount of time over which the pitch transition is to occur while Portamento is turned on. The acceptable range is 0-127. The higher the value, the longer the pitch transition time.

- 1 Hold down [PORTAMENTO], and use either the VALUE slider or VALUE [▲] [▼] to set the Portamento Time.

```
Portamento Time
127
```

- 2 Release your finger from [PORTAMENTO], and the Portamento Time is stored in memory.

5 Bender/Modulation Lever

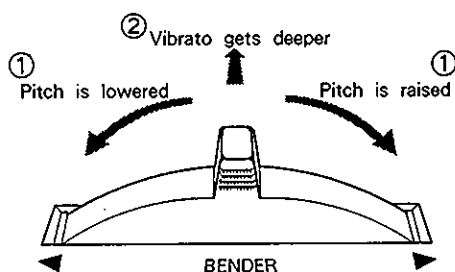

The Bender/Modulation Lever located on the left side of the keyboard is used as follows:

- 1 When moved to the left/right it lowers/raises the pitch of what is played.
- 2 When pushed toward the rear, it adds a vibrato effect. The lever can be conveniently used to duplicate such techniques as string bending on a guitar, or to simulate certain breath techniques that would occur with a wind instrument. You may want to practice with the lever a while, however, until you get precisely the effect you need.

* Concerning the settings available for Bend Range and Vibrato Depth, refer to "Setting Performance Functions for Individual Parts" (» p.22).

- ▶ Bend Range: the range over which the pitch is can be changed.
- Vibrato Depth: depth to which the Vibrato effect is applied.

Setting Performance Functions Applying to All Parts

The following explains how to make the settings for functions which apply equally to all Parts at once.

[Making the Settings]

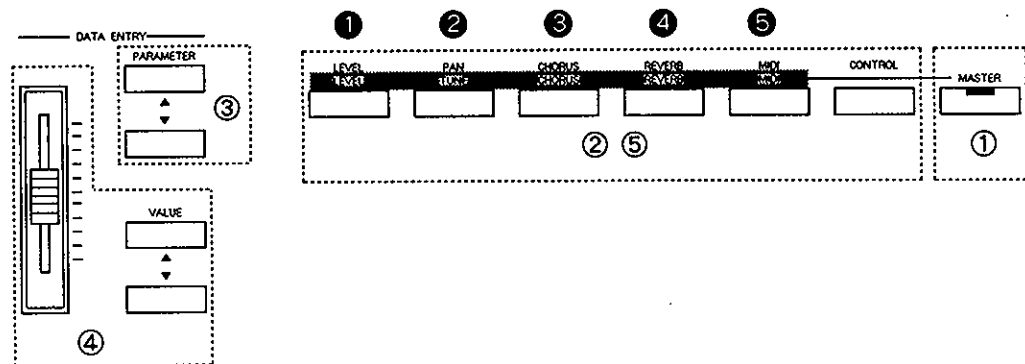

- ① Press [MASTER], and confirm that the indicator is lit.
 - ② Press the button (indicated in blue on the lower row) for the function for which you wish to make a setting change.
 - ③ Should there be several items available for the selected function, switch among them using PARAMETER [▲] [▼]. The function and its value will be shown in the display.
 - ④ Use either the VALUE slider or VALUE [▲] [▼] to select the new value.
 - ⑤ Once you are through making settings, once again press the button for the function selected in step ②.
- * To make changes in the settings for other functions, repeat steps ②-④.
* Any setting changes you make for the above remain stored in memory, even while the power is off.

① Level

Master Level 100

Sets the overall volume. The acceptable range is 0-127.

② Tune

Master Tune 440.0

Adjusts the pitch. As the value is decreased, the pitch is made lower; while higher values raise the pitch. The pitch can be adjusted within the range of 415.3 to 466.2 Hz.

Setting Performance Functions Applying to All Parts

③ Chorus

Provides selection of the Chorus Level and the Type for it.

Chorus Level 30

The acceptable range for the Level is 0-127.

The following 8 Types are available:

Chorus Type
Short Delay

Type	Effect
Chorus 1/2/3/4	Standard chorus effect.
Feedback Chorus	Chorus effect that simulates a flanger with soft sound.
Flanger	An effect that is sometimes used to simulate the takeoff and landing of a jet.
Short Delay	A delay repeated in a short time.
Short Delay (FB)	A short delay repeated many times.

④ Reverb

Provides selection of the Reverb Level and the Type for it.

Reverb Level 30

The acceptable range for the Level is 0-127.

The following 8 Types are available:

Reverb Type
Plate

Type	Effect
Room 1/2/3	Reverb that simulates the natural echo of a room. Sharply-defined reverb with a broad spread.
Hall 1/2	Reverb that simulates the natural echo of a hall. Smooth reverb, with greater depth than room.
Plate	This effect simulates Plate Echo (a type of reverb that uses the vibration of metal plates to produce a metallic echo).
Delay	Standard delay effect.
Panning Delay	Delay repetitions pan to left and right. This effect can be used if the unit is connected to a stereo audio device. It is effective when the JV-30 is connected to a stereo system.

⑤ MIDI

These settings are for functions which come into play when you connect this instrument with another MIDI-equipped unit. For details, refer to "MIDI Settings" (» p.34).

Setting Performance Functions for Individual Parts

The following explains how to make the function settings which can be made individually for each of the Parts.

[Making the Settings]

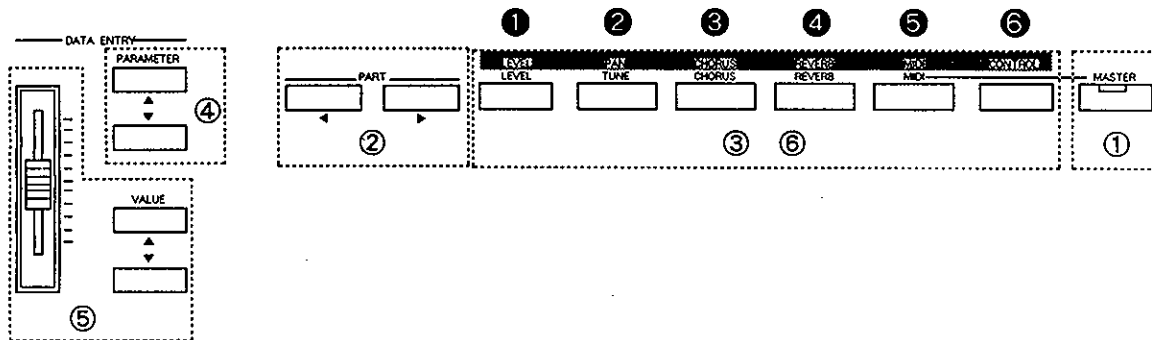

- ① Press [MASTER], and confirm that the indicator go off.
- ② Using PART [◀] [▶] select the Part for which you wish to change settings.
- ③ Press the button (indicated in white on the upper row) for the function for which you wish to make a setting change.
- ④ Should there be several items available for the selected function, switch among them using PARAMETER [▲] [▼]. The function and its value will be shown in the display.
- ⑤ Use either the VALUE slider or VALUE [▲] [▼] to select the new value.
- ⑥ Once you are through making settings, once again press the button for the function selected in step ③.

* To make changes in the settings for other functions, repeat steps ②-⑤.
 * Any setting changes you make remain stored in memory, even while the power is off.

① Level

```

1▶Piano 1
Part Level: 100
  
```

Sets the sound volume for each of the Parts. The acceptable range is 0-127.

② Pan

```

1▶Piano 1
Pan: L60 R
  
```

Allows you to adjust the pan position (localization of sound image) for each of the Parts, obtained when using a stereo output. With an increase in the value for L, more of the sound will be heard as coming from the left side. Similarly, more of the sound will be heard as originating at the right if the value of R is increased. When set to RND (Random), you obtain a specialized effect whereby the sound randomly moves left and right with each note played.

* Within Drum Sets, the localization is already fixed to what is considered appropriate for each percussive sound. For this reason, if you change Pan for a Part using a Drum Set, the sound localization for the whole set will move.

③ Chorus Send Depth

```

1▶Piano 1
Chorus Depth: 50
  
```

Sets the manner in which Chorus will be applied to each Part. The acceptable range is 0-127.

Setting Performance Functions for Individual Parts

4 Reverb Send Depth

```
1▶Piano 1
Reverb Depth: 40
```

Sets the manner in which Reverb will be applied for each Part. The acceptable range is 0-127.

5 MIDI

These settings are for functions which come into play when you connect this instrument with another MIDI-equipped unit. For details, refer to "MIDI Settings" (» p.34).

6 Control

Allows settings to be made for the following functions:

○ Bend Range

```
1▶Piano 1
Bend Range: +10
```

Determines the amount of pitch change obtained when the Bender/Modulation Lever is moved to either the left or right extreme. The setting is in semitones, and a maximum of 2 octaves is possible (0 to +24).

○ Modulation Depth

```
1▶Piano 1
Mod Depth: 20
```

Sets the depth of the vibrato obtained when the Bender/Modulation Lever is pushed all the way to the rear. The range for the value is 0-127. The higher the value, the deeper the vibrato becomes.

○ Key Shift

```
1▶Piano 1
Key Shift: + 2
```

Allows the pitch to be shifted in semitones. The setting can be within the range of ± 2 octaves (-24 to $+24$).

○ Velocity Sens Depth

```
1▶Piano 1
Velo Depth: 64
```

On the JV-30, the strength (velocity) with which you play the keyboard is translated into alterations in the volume or timbre of the sound. The Velocity Sens Depth setting determines the extent to which such alterations will occur. With the setting at a high value, the changes in volume will be quite pronounced; whereas if set to "0," there will be no change in volume no matter how hard you play the keys. The range of the value is 0-127.

○ Velocity Sens Offset

```
1▶Piano 1
Velo Offset: 64
```

This setting determines the approximate velocity at which the keys should be struck in order to obtain alterations in the volume. With values greater than 64, volume fluctuation occurs even when the keys are pressed lightly. With values lower than 64, volume fluctuation occurs when the keys are pressed firmly. The range of the value is 0-127.

*** Sounds may not be output depending on the settings. If this occurs, set the Velocity Sens Depth or Velocity Sens Offset to higher values.**

○ Voice Reserve

```
Voice Reserve
Part1: 3( 2)
```

↑
The rest of
voice number

The Voice Reserve number (current part)

This setting determines the minimum number of voices that will always be reserved and made available for a certain Part. This is for situations where the total number of voices being sounded has exceeded the JV-30's maximum polyphony.

For example, if Voice Reserve is set to "6" for a particular Part, that Part will always be able to sound at least 6 voices, even when the unit as a whole is being requested to produce more voices than it is capable of.

*** Since the JV-30 is capable of producing 24 voices simultaneously, the values set for Voice Reserve for all Parts combined must add up to 24 (or less).**

Editing Tones

The JV-30 allows you to make changes in the settings for a Tone, then store it as an original Tone. Such edited Tones are stored in memory as User Tones.

- * Any changes made in the settings for a Tone will only be temporary. Once another Tone is selected, the settings will revert to their original values. Should you wish to retain the setting changes you have made, they need to be stored in memory by performing the Write Procedure.
- * The procedures explained here will not work for Drum Sets. To change the settings for Drum Sets, refer to "Editing Drum Sets" (» p.26).

[Altering the Settings]

Tones are edited by making changes in the settings for their 8 parameters (editable items). These parameters belong to one of three groups: Vibrato, Filter, or Envelope, depending on their purpose.

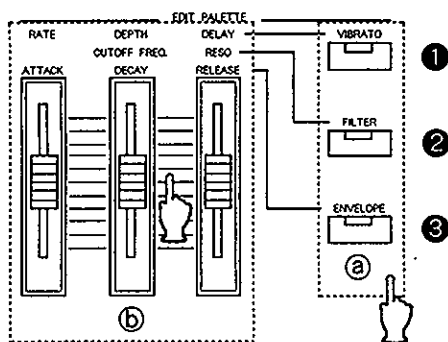

- ① **Select the Tone which you wish to edit.**
Both User and Preset Tones can be selected.
- ② **Using buttons (a), select the parameter group.**
The indicator on the button which has been pressed will light.
- ③ **Using sliders (b), alter the value for the parameter.**
Depending on the group selected, the parameters which can be edited with each of the sliders will change.
Once the value for a parameter has been changed, the indicator on either [PRESET] or [USER] will start blinking. This indicates that a change in value has been made.
To return to the stage you were originally in, press whichever button in (a) that is lit.

* Changes in Tone values can also be made using PARAMETER [▲] [▼], the VALUE slider, or VALUE [▲] [▼].
Use PARAMETER [▲] [▼] to select the parameter, then alter the value using the VALUE slider or VALUE [▲] [▼].

[Parameters and Their Functions]

① Vibrato

The following settings affect the manner in which Vibrato is applied.

● Vibrato Rate

```
1▶Piano 1
Vib. Rate: +30
```

Adjusts the speed of the vibrato. Range: -50 to +50.
The higher the value, the faster the vibrato becomes.

● Vibrato Depth

```
1▶Piano 1
Vib. Depth: +30
```

Adjusts the depth of the vibrato. The higher the value, the deeper the vibrato becomes.
Range: -50 to +50. The higher the slider is raised, the deeper the vibrato becomes.

● Vibrato Delay

```
1▶Piano 1
Vib. Delay: +20
```

Provides an adjustment for the amount of time that is to pass between the moment a key is pressed, and the moment that Vibrato begins to take effect.
Range: -50 to +50. The higher the value, the longer the time becomes.

② Filter

The following settings affect the nuance of a sound by applying changes to its harmonic structure.

● Cutoff Frequency

```
1▶Piano 1
Cutoff Freq.:+10
```

Sets the frequency at which the harmonic content will be cut. Range: -50 to +16. The lower the value, the more "pleasant" the sound becomes.

● Resonance

```
1▶Piano 1
Resonance: +20
```

Provides an adjustment for the amount of emphasis that is to be placed on the harmonic content in the vicinity of the Cutoff Frequency. Range: -50 to +50. The higher the value, the more distinctive the sound becomes.

③ Envelope

The following settings adjust the volume and the change that occurs over time in the Cutoff Frequency.

● Attack Time

```
1▶Piano 1
Attack Time: +10
```

Adjusts the time it takes for the initial portion of a sound to be heard after a key is pressed. Range: -50 to +50. The higher the value, the slower the attack becomes.

● Decay Time

```
1▶Piano 1
Decay Time: +10
```

Adjusts the time it takes before the "Sustain Level" for the sound is reached, after the Attack has finished. Range: -50 to +50. The higher the value, the longer the time becomes.

● Release Time

```
1▶Piano 1
Release Time:+10
```

◆ **Sustain Level: The level at which volume/cutoff frequency changes stabilize.**

Adjusts the time it takes before the sound will fade away after a key is released. Range: -50 to +50. The higher the value, the longer the time becomes.

Storing Edited Tones

The "Write Procedure" must be performed in order to retain the changes you make to a Tone. The destination for an edited sound is a User Tone located at the same Bank/Number as the currently selected Tone.

```

[PRESET] : BANK [1] + NUMBER [5]
           : BANK [1] + NUMBER [5] + [VARIATION] → [USER] : BANK [1] + NUMBER [5]
[USER]   : BANK [1] + NUMBER [5]
                                     Write Procedure
    
```

[Write Procedure]

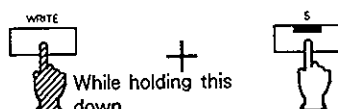

Hold down [WRITE] and press the NUMBER [1]-[8] button that is blinking, to write the edited Tone into memory. If you let up on the [WRITE] before pressing a NUMBER [1]-[8], then nothing happens and the Write Procedure is canceled.

- * User Tones do not have any Variations. If you create a sound that is an edited version of a Variation, you need to write it to the Number button where that Variation belongs.
- * Care should be taken when performing the Write Procedure, since any Tone that was previously stored at the destination will be overwritten (erased).

Editing Drum Sets

The JV-30 allows you to make changes in the percussive sounds in the currently selected Drum Set. The edited sounds can be stored as part of a new Drum Set.

Drum Sets have a number of parameters (editable items) which can be altered using the buttons and sliders.

[Altering the Settings]

Drum Sets are edited by making changes in the settings for their 4 parameters.

- 1 Select the Drum Set which you wish to edit.
Both User and Preset Drum Sets can be selected.

- 2 Press PARAMETER [▲] and [▼] simultaneously.

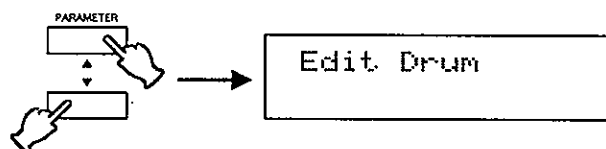

- 3 Press the key on the keyboard corresponding to the percussive sound you wish to edit.
The percussive sound's name and its position on the keyboard will be shown in the display.

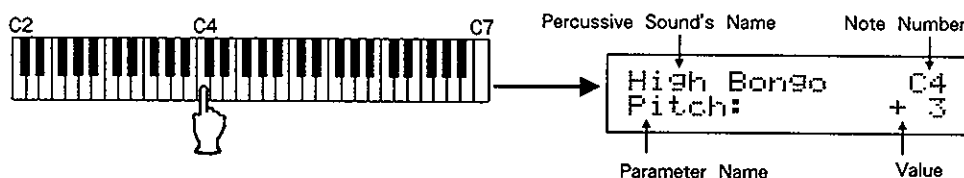

- 4 Use PARAMETER [▲] [▼] to select the parameter.

The parameter's name and its value will be shown in the display.

- 5 Alter the parameter's value using the VALUE slider or VALUE [▲] [▼].

Once the value for a parameter has been changed, the indicator on either [PRESET] or [USER] will start blinking.

This indicates that a change in value has been made.

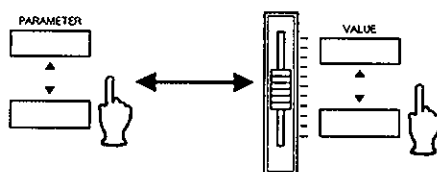

- 6 To exit the Drum Set editing mode, simultaneously press PARAMETER [▲] and [▼].

* When you wish to edit a percussive sound assigned to a note lying beyond the range of the keyboard, first use the Transpose function to shift the keyboard's playing range (» p.18).

* Any changes made in the settings for a Drum Set will only be temporary. Once another Drum Set is selected, the settings will revert to their original values. Should you wish to retain the setting changes you have made, they must be stored in memory by performing the Write Procedure.

[Parameters and Their Functions]

① Pitch

High Bongo	C4
Pitch:	+ 3

Adjusts the pitch of the percussive sound in semitone units. The setting can be within the range of ± 2 octaves (-24 to +24).

② Level

High Bongo	C4
Level:	127

Adjusts the volume of the percussive sound . The acceptable range is 0-127.

③ Pan

High Bongo	C4
Pan:	L231 R

Allows you to set the pan position (localization of sound image) for each of the percussive sounds, obtained when using a stereo output. With an increase in the value for L, more of the sound will be heard as coming from the left side. Similarly, more of the sound will be heard as originating at the right if the value of R is increased. When set to RND (Random), you obtain a specialized effect whereby the sound randomly moves left and right with each key played.

④ Reverb Depth

High Bongo	C4
Reverb Depth:	30

Sets the manner in which Reverb will be applied. The acceptable range is 0-127.

Storing Edited Drum Sets

The Write Procedure allows you to retain the changes you make to a Drum Set by storing them in memory. The destination for edited Drum Sets will be a User Drum Set located at the same button as the currently selected Drum Set.

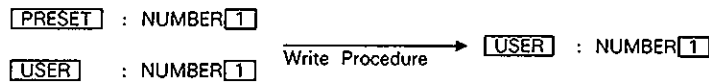

[Write Procedure]

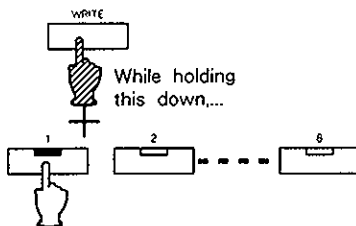

Hold down [WRITE] and press the NUMBER [1]-[8] button that is blinking, or press [VARIATION], to write the edited Drum Set into memory. If you let up on the [WRITE] before pressing a NUMBER [1]-[8] or [VARIATION], then nothing happens and the Write Procedure is canceled.

* Care should be taken when performing the Write Procedure, since any Drum Set that was previously stored at the destination will be overwritten (erased).

Performances

The JV-30 allows you to save a whole group of settings (for a range of functions) as one unit referred to as a "Performance." The following explains how to make the settings for, and how to use such Performances.

● Performances Explained

In its basic form, the JV-30 can be played by simply pressing the necessary panel buttons to change Tones, or to turn desired effects on or off. However, considering the numerous features offered, and the number of settings required, it is difficult to skillfully make wide-ranging changes while playing the instrument. For this reason, it is much more convenient to make use of Performances.

A Performance can store information on all the settings for the buttons illustrated below. Up to 8 such Performances can be placed in memory.

A Performance which provides exactly the settings you need can be prepared and stored beforehand. Then, while playing, the whole collection of choices can be selected instantaneously, simply by selecting the Performance.

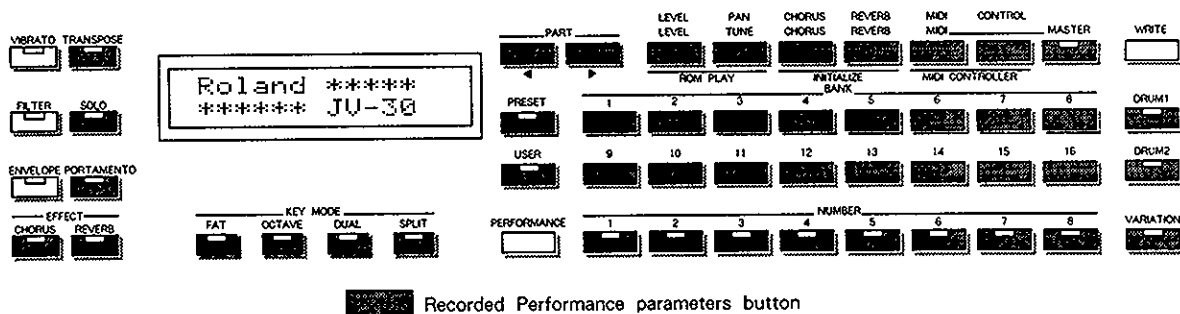

[Selecting a Performance]

While holding down [PERFORMANCE], press NUMBER [1]-[8].
The JV-30 will be set to comply with all settings contained in the selected Performance.

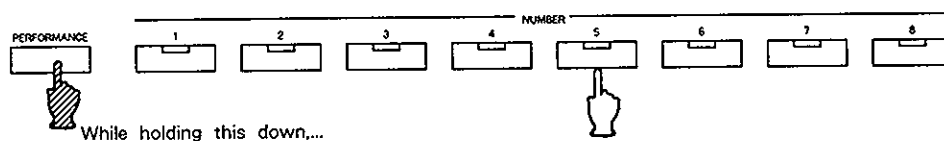

[Storing a Performance in Memory]

- ① Make all the settings for all the features you wish to be stored in the Performance.
- ② While holding down [WRITE], press [PERFORMANCE]. Then, while still holding down [WRITE], press NUMBER [1]-[8], whichever one is to be the destination for the Performance.

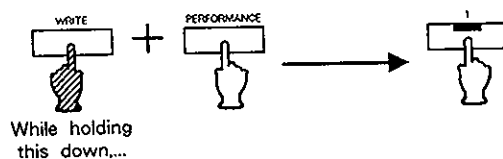

- * If you remove your finger from [WRITE] before pressing NUMBER [1]-[8], you will be returned to the previous level, and the Performance settings will not be stored.
- * Care should be taken when storing Performances, since any settings previously stored at the same destination will be overwritten (erased).

Section II

USING MIDI

Using MIDI 1

[About MIDI]

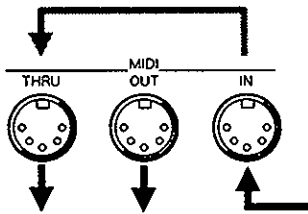

MIDI (Musical Instrument Digital Interface) is an internationally recognized standard formulated to provide for the transfer of performance information among electronic musical instruments and computers. When MIDI, music is not handled as sound itself. Instead, performance information and whatever commands accompany it are converted and expressed in digital form. Any device equipped with MIDI connectors, regardless of differences in model or manufacturer, can exchange whatever performance data they are both equipped to understand, once MIDI cables have been used to make the correct connections. For example, the JV-30 can be used to play another separate keyboard, or a sequencer could provide the data necessary to play the JV-30.

[Making the Connections]

● Playing the JV-30 and Another Unit Simultaneously

Connect the units together as shown below. Then, whenever you play the JV-30, not only will it sound, but the other unit will receive that performance information and play the same notes. This type of connection is referred to as the "One-way" method.

The unit that transmits the performance information is called the "master," whereas the unit receiving the information is known as the "slave."

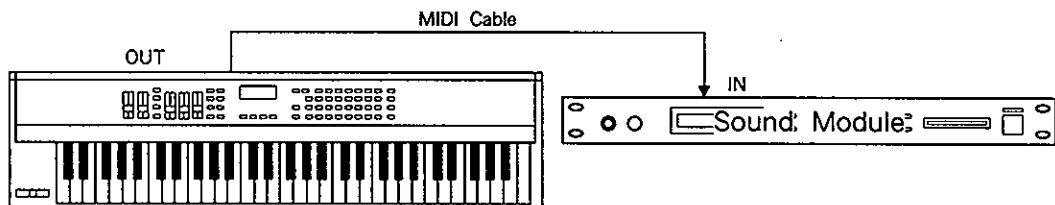

● Connecting the JV-30 to a Sequencer

Connect the JV-30 and a sequencer (such as the MC-50) as shown below. Then, once you get the sequencer ready to record, whatever performance information you generate (play) using the JV-30's keyboard will be recorded into the sequencer.

If your sequencer provides a Soft Thru function, you should turn it ON. Local Control (» p.35) on the JV-30 should also be OFF. (If your sequencer doesn't provide Soft Thru function, you should turn it ON.) This type of connection is considered as an alternate form of the "One-way" method. When recording, the JV-30 is the master, and the sequencer is the slave. During playback, their roles are reversed.

The connections can be made in the same way when using a computer-based sequencer.

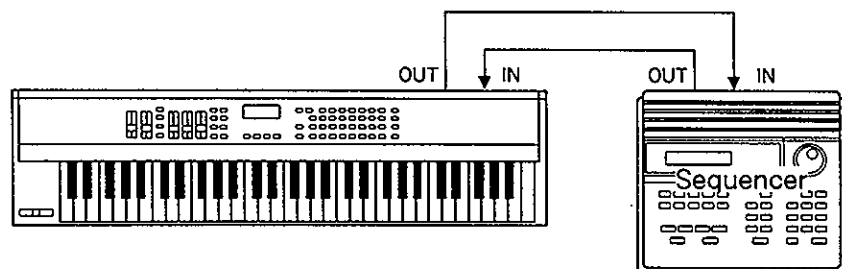

● Simultaneously Controlling Two or More MIDI Devices

As illustrated below, connect a cable between the MIDI OUT on the JV-30, which becomes the master, and the MIDI IN on Slave 1. Then, connect the MIDI THRU on Slave 1 with the MIDI IN on Slave 2.

When connected in this manner, the performance information from the master is sent to Slave 1 and Slave 2, so whatever is played on the master keyboard will also be sounded by Slaves 1 and 2.

This method is referred to as a "Series Network".

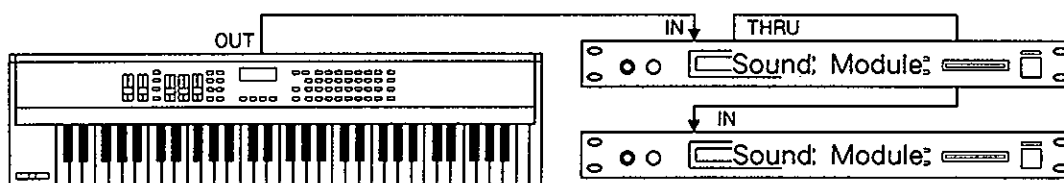

However, this method may be unsatisfactory, because the further from the master that the device is located, the more delay there is that could occur. Signal deterioration is also a consideration.

If connection of 4 or more devices is required, we recommend that you use a MIDI Patch Bay (eg., A-880, available separately), and make the connections as illustrated below.

This method is referred to as a "Star Network".

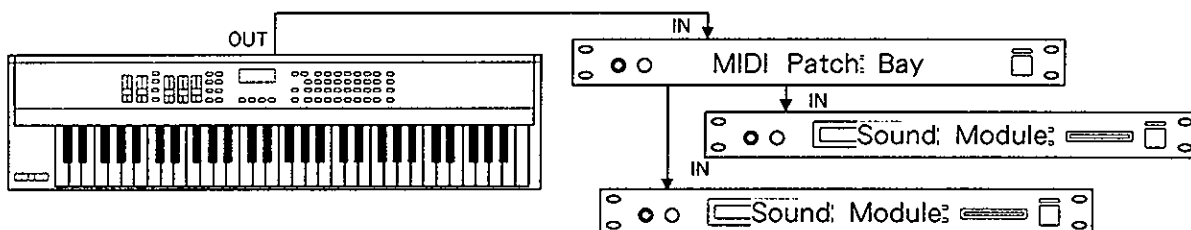

Using MIDI 2

[Concerning MIDI Channels]

With MIDI, a single cable can be used to transfer an enormous amount of performance information. This is possible thanks to the concept of MIDI channels. MIDI channels can in some ways be considered as similar to the channels on a television set. On a television, any of the broadcasts from different stations can be selected by switching channels. The information on any particular channel is conveyed only when the receiver is set to the same channel that is being used for transmission.

Similarly, when a receiving device is set so its MIDI channel matches the channel used by the transmitting device, the MIDI data on that channel is conveyed.

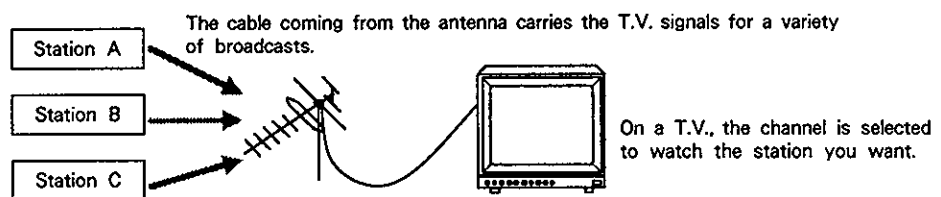

However, in one important aspect, the JV-30 is quite different from television. One can only view one channel at a time on a television, whereas on the JV-30, all of the performance information on all 16 channels can be played at the same time. This is because the unit has 16 Parts, and each of them is a separate sound generator. Synthesizers which are designed in this manner are referred to as being "multi timbral."

[Concerning the Types of Data Handled Over MIDI]

In order to convey the great variety of expression possible with music, MIDI contains a large range of data types (messages). MIDI messages can be divided into two main types:

Messages handled on each channel : Channel messages
Messages handled independently of channels: System messages

● Channel Messages

These messages are used to convey the musical events of a performance. The great majority of MIDI data is of this type.

○ Note Messages

These messages are sent out whenever anything is played on the keyboard. Note messages include the following:

Note Number: Number representing the position of the key pressed.
Velocity : Strength with which the key was pressed.
Note On : Key was pressed
Note Off : Key was released

○ Pitch Bend Messages

Messages which convey the action of the Bender/Modulation Lever.

Aftertouch Messages

These messages convey the amount of pressure that is further put on a key after it has initially been pressed. There are two types of Aftertouch; Channel and Polyphonic. Channel Aftertouch provides control based on each MIDI channel, whereas Polyphonic Aftertouch manages the information on an individual key basis. Although the JV-30 cannot transmit Aftertouch messages, it is capable of responding to both types of Aftertouch messages when received from an external device.

Reception of channel aftertouch and polyphonic aftertouch on the JV-30 is disabled in the default factory setting or when receiving a GS reset message. When you wish to use these functions, set them by transmitting exclusive message from external MIDI device. See the MIDI implementation chart for more details.

Program Change Messages

These messages convey information about changes in the sound used.

Control Change Messages

These messages are used to enhance the expressiveness of a performance, and include Vibrato, Hold, Volume, and Pan. On the JV-30, a value of "0" for the Control Number is employed to change Variations.

System Messages

System Messages include Exclusive messages; data concerned with synchronized play, as well as diagnostic-use data. On the JV-30 it is mainly Exclusive messages that are recognized.

Exclusive Messages

Exclusive messages handle information such as that related to a device's own unique sounds. Generally, such messages can be exchanged only between devices of the same model (by the same manufacturer).

On the JV-30 they are mainly useful for storing Tone and system function data, and the settings for Parts into a sequencer.

*** Whenever Exclusive messages are to be used for communication, both devices need to be set to the same Unit Number (» p.35).**

Concerning MIDI Implementation Charts

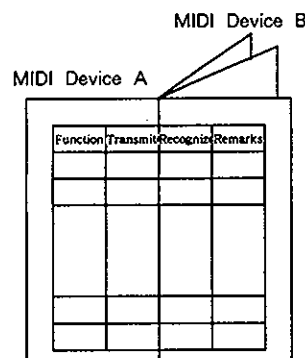

MIDI makes it possible for a wide range of musical data to be communicated, but there are many differences between devices. For this reason every owner's manual includes a MIDI Implementation Chart, which you should look at to determine the types of MIDI messages it is capable of handling. Wherever a "○" appears, the unit is capable of handling that type of data.

MIDI Settings

By making use of MIDI, the JV-30 can be used as a multi timbral sound source, or can be used as a master keyboard that controls a number of other units. The following explains the settings that become necessary when you wish to use MIDI.

[How to make the settings]

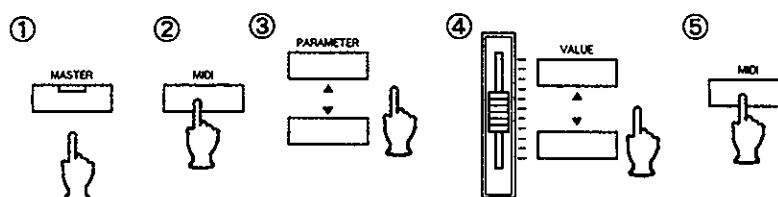

- ① When making MIDI settings common to all Parts, press [MASTER], and confirm that the indicator is lit.
When making MIDI settings for individual Parts, press [MASTER], and confirm that the indicator go off.
- ② Press [MIDI].
- ③ Use PARAMETER [▲] [▼] to select the parameter you wish to set.
The parameter's name and its current value will be shown in the display.
- ④ Alter the parameter's value using the VALUE slider or VALUE [▲] [▼].
- ⑤ When finished, press [MIDI].

* To make changes in the settings for other functions, repeat steps ③-④.
* Any setting changes you make remain stored in memory, even while the power is off.

[Parameters Available for Setting]

● MIDI Settings Common to All Parts

○ Transmit Channel

```
MIDI Function
Tx Channel: Part
```

Sets the channel the JV-30 will use to transmit data. Once a channel from 1-16 is selected, the JV-30 will transmit its performance data on that channel. If set to "PART," the unit will instead transmit data out on an individual Part basis, on the same channel that each Part is set to receive on.

○ Tone Change Receive Switch

```
MIDI Function
Rx Tone Chg: ON
```

This setting determines whether or not data concerning changes in the sound used will be accepted. When ON, the JV-30 will change its Tones in compliance with whatever Tone Change messages it receives from an external device. When OFF, all such Tone Change messages will be ignored, so changes in the sound will not occur.

○ GS Reset Receive Switch

```
MIDI Function
Rx GS Reset: ON
```

This setting determines whether or not All Reset data, which will initialize all the unit's settings to their defaults, will be accepted.

Exclusive Receive Switch

```
MIDI Function
Rx SysEx:    ON
```

This setting determines whether or not Exclusive messages will be accepted. When ON, the JV-30 will change its settings, etc., in compliance with whatever Exclusive messages it receives from an external device. When OFF, any messages directing the unit to change its settings that may arrive from an external unit will be ignored.

Aftertouch Receive Switch

```
MIDI Function
Rx After:    ON
```

This setting determines whether or not Aftertouch messages will be accepted.

Local Control

```
MIDI Function
Local       ON
```

The Local Control switch determines whether the keyboard control section (includes keyboard, switches, and bender) and the sound source are connected or not. When OFF, the sound source and the keyboard will no longer be connected, so the JV-30 will not produce sound when its keyboard is played. However, everything played will be transmitted as data from MIDI OUT. Also, regardless of the setting for Local Control, the JV-30 will accept, and play on its sound source, whatever performance data it receives from an external unit.

*** To prevent any confusion regarding instances where the unit might seem to be unable to produce sound, it is automatically set to Local ON each time the power is turned on or use the Key Mode.**

Performance Dump Switch

```
Performance Dump
Tx :         ON
```

This setting determines whether or not data for the Performance will be sent out when [PERFORMANCE] + [1]-[8] are pressed. When set to ON, the data for Performance 1 will be sent out when [PERFORMANCE] + [1] is pressed, for example.

Device ID Number

```
MIDI Function
Device ID#:  17
```

This setting, an identification number given to the unit, allows several units to be distinguished from one another when a multiple number of identical units are being used. This number is contained within Exclusive messages, and allows units to receive only the Exclusive messages intended for them. The setting can be from 1-32. The default value is 17.

Bulk Dump/Tone Dump/Drum Tone Dump

Performs the transmission of various JV-30 data. For details, refer to "Saving the JV-30's Data" (» p.40).

```
Bulk Dump
Sure?      [WRITE]
```

```
Tone Dump
Sure?      [WRITE]
```

```
Drum Tone Dump
Sure?      [WRITE]
```

● MIDI Settings for Individual Parts

Receive Channel

```
1▶Piano 1
Rx Channel:  10
```

This setting, made for each Part, determines the channel the Part will use to receive data. Can be set to any channel from 1-16. When set to OFF, that particular Part will not receive any MIDI message that arrives from an external unit.

Bulk Dump

```
Bulk Dump Sure?
Part 1     [WRITE]
```

Allows for the Bulk Dump of data for each of the Parts. For details, refer to "Saving the JV-30's Data" (» p.40).

Making Full Use of the Multi Timbral Features

The JV-30 also functions as a multi-timbral sound module that offers 16 Parts. In order to get the most out of the instrument, you need to connect it with other devices, such as a sequencer, and hear for yourself how well it performs ensembles.

For our purposes here, it is assumed that a sequencer (Roland MC-50, MC-500 MkII, or similar unit) is used for recording/playback. For details on the use of the sequencer, refer to its owner's manual.

① Make the connections

After referring to "Connecting the JV-30 to a Sequencer" (» p.30), connect the sequencer with the JV-30. Once connected, turn on power first to the JV-30, then the sequencer. Set Local Control on the JV-30 to OFF, and Soft Thru (**) on the sequencer to ON. (If the sequencer does not have a Soft Thru function, the JV-30 should be left at Local ON.)

▶ Refer to the owner's manual for your sequencer for information on the Soft Thru feature.

② Select the Tones

Select a Tone for each of the JV-30's Parts. For our purposes here, we will set up an orchestra, demonstrating the creative use of all 16 Parts. Part 10 will be the Drum Part. Please refer to the diagram below and select the Tones.

PART 1	Violin	PART 9	Bassoon
PART 2	Viola	PART 10	DRUM 1 (ORCHESTRA Set)
PART 3	Cello	PART 11	Horn
PART 4	Contrabass	PART 12	Trumpet
PART 5	Piccolo	PART 13	Trombone
PART 6	Flute	PART 14	Tuba
PART 7	Clarinet	PART 15	Piano 1
PART 8	Oboe	PART 16	Harp

* When set to the factory defaults, Part 10 is set as the Drum Part.

③ Start Recording

Refer to "MIDI Settings Common to All Parts," and set the JV-30's Transmit channels. You will probably find it convenient to have the unit set so the Parts have a numerical correspondence with their respective MIDI Transmit channels.

Once ready, you can begin recording for each Part.

Have the sequencer ready to record, then input the music for each Part from the keyboard. It is probably best to do the Drum Part first, then listen to it while you work with the rest.

Since it is difficult to record drums while playing on the keyboard, you could use step time input to enter them into the sequencer, or you could play them using a separate rhythm machine (Roland R-8, R-5, CR-80, etc.).

If you set the Key Mode to SPLIT, you can record what is played using two Parts at the same time. In addition, you may want to use the Bender/Modulation Lever, or other controls during recording, since such data will also be included in the recording.

Making Full Use of the Multi Timbral Features

④ Creation of the most satisfactory Performance

Once you have finished the recording of the whole piece, try listening to the playback. While listening, try selecting other Tones; and similar to using a mixer, adjust the overall balance by changing Level or Pan settings. As finishing touches, make adjustments for Chorus and Reverb. When completed, it can be stored as a Performance.

Once stored as a Performance, a Performance Change message can be sent at the beginning of the song, and you will be able to record knowing that you have the optimum balance.

⑤ Changing Tones partway through a song

If you make a change in the Tone while recording, not only will the sound change, but also the Variation Number (0 for a Capital Tone), Program Change Number, and Tone Edit Data which corresponds to the selected Tone will be transmitted.

Since a large volume of data is sent out at such times, you may notice upon listening to the playback that the timing of Tone changes has shifted somewhat. In order to prevent such timing problems, it is better to first record only the music, and then overdub afterwards to insert the Tone changes.

● Maximum Polyphony and Part Priority Ordering

[Concerning the Maximum Polyphony]

The JV-30 is capable of producing 24 voices simultaneously. However, when using Tones composed of 2 voices, this maximum number of voices is reduced to 12. Also, if using a Key Mode, the maximum polyphony will change, since 2 Tones are played together. For information on the number of voices used by particular Tones, refer to the "Tone Table" (» p.52).

[Concerning Part Priority Ordering]

Note Sounding Priority order	Part number
1	10 (Drum part)
2	1
3	2
4	3
5	4
6	5
7	6
8	7
9	8
10	9
11	11
12	12
13	13
14	14
15	15
16	16

When the number of voices being sounded exceeds 24, priority is given to producing the most recent sounds. Those that have already been sounding for a while will be cancelled out to make room for the newest notes. The JV-30 follows a priority ordering system, whereby the Part having the lowest priority will be the one that has to stop producing sounds first; and thereon up through the order of priority. For this reason, you should take a Part's order of priority into consideration when assigning it for use in songs.

For sounds that you definitely must have produced, use the Voice Reserve function (» p.23) to set an appropriate number of voices for them.

MIDI Controller Features

The JV-30 allows you to add further expression to songs while they are played by, or recorded onto a sequencer. This can be accomplished thanks to the MIDI Controller Features, which allow you to use the sliders for control over whatever parameters you wish. For example, you can apply continuing changes in the volume of Parts to add excitement, pan the sound left and right, or make many other creative alterations in parameter values. The sliders thus make easy the recording of many operations which would take much longer using conventional methods of entry into a sequencer.

Perform the following to use the MIDI Controller features creatively in songs.

[Procedure]

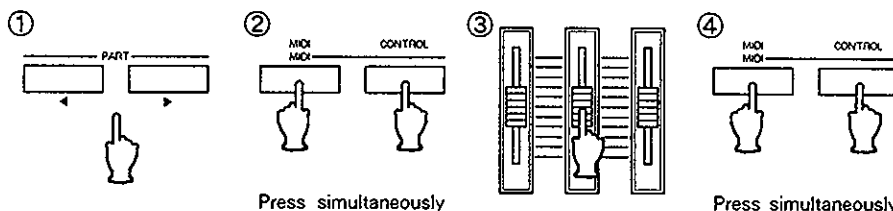

- ① Using PART [◀] [▶], select the Part for which you wish to change the volume (expression) or panning.
- ② Press [MIDI] and [CONTROL] simultaneously.
- ③ Have the sequencer ready to record, then move the sliders to change the volume, or pan the sound while recording.
- ④ To return to where you were originally, once again press [MIDI] and [CONTROL] simultaneously.

Parameters are assigned to the three sliders as shown below. The Control Number determines what is to be assigned, and is set using VALUE [▲] [▼]. For details, refer to the "MIDI Implementation."

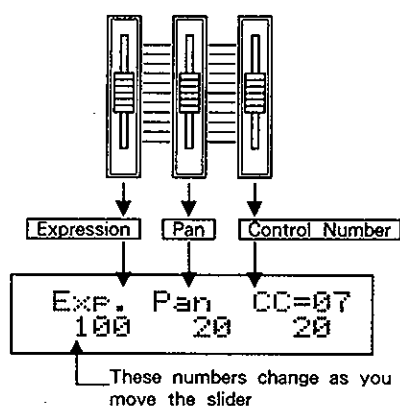

The range for each parameter is as shown below:

Expression	0~127
Pan	0~127 (L63~R63)
Value for the indicated Control Number	0~127

* The Control Numbers which can be specified are: 0-9, 12-31, and 64-95.

Restoring the Original Settings

On the JV-30 you can always revert to any the following three choices of original settings, even after making revert wide-ranging changes in settings, and revising numerous sounds.

(1) Restore all settings to their factory defaults (Initialization).

```
Initialize Sure?  
All [VALUE▲]
```

(2) Restore settings for User Tones and User Drum Sets to their factory defaults.

```
Initialize Sure?  
Tone/Dr. [VALUE▲]
```

(3) Restore the original GS Format settings.

```
Initialize Sure?  
GS [VALUE▲]
```

[Procedure]

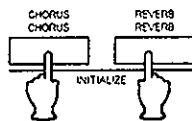

Press simultaneously

- ① Press [CHORUS] and [REVERB] simultaneously.
- ② Using PARAMETER [▲] [▼], make the type selection from (1)-(3).
- ③ Press [VALUE] [▲], and the specified initialization will be carried out.
To cancel the procedure, press VALUE [▼] instead.

Obtaining MT-32 Sound Ordering

The JV-30 contains an MT-32 (Multi Timbral Sound Module) simulation mode. This makes it convenient for connecting with computer music systems, for which the MT-32 is a well-known, widely-used unit. For Part 10, the CM-64/32L Drum set is selected automatically. When wishing to play sound data intended for the MT-32, simply perform the procedure below.

```
Initialize  
MT-32
```

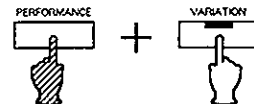

While holding this down....

While holding down [PERFORMANCE], press [VARIATION].

* To return to the JV-30's normal sound order, press PERFORMANCE [1]-[8]. Or while still set to MT-32 sound ordering, turn the power off. The next time the power is turned on, the unit will be at the Performance 1 settings.

* For details of the MT-32 sound ordering, refer to p.55.

Saving the JV-30's Data

The JV-30's Data can be saved in the form of Exclusive message onto an external MIDI device. To save data in this manner, you need to perform what is referred to as the Bulk Dump procedure. The following explains the different types of Bulk Dump available, and how they are performed.

[Connections]

The JV-30 must be connected to an external MIDI device, either a sequencer or other type of unit. MIDI cables should be connected as illustrated below.

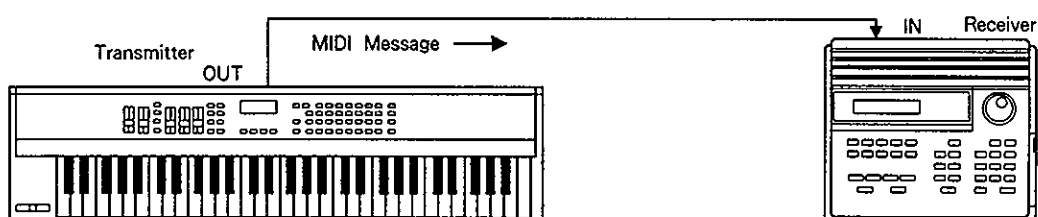

* If instead of a sequencer, you connect another JV-30, both of them can be set to exactly the same settings.

[Bulk Dump Types]

The following types of Bulk Dump are available:

● Bulk Dump

```
Bulk Dump
Sure? [WRITE]
```

Transmits all of the JV-30's settings.

● Tone Dump

```
Tone Dump
Sure? [WRITE]
```

Transmits the settings for the 128 User Tones.

● Drum Tone Dump

```
Drum Tone Dump
Sure? [WRITE]
```

Transmits the settings for the User Drum Sets.

● Bulk Dump (Part)

```
Bulk Dump Sure?
Part 1 [WRITE]
```

Dumps the settings for Parts, or for individually selected Parts.

[Performing a Bulk Dump]

(1) Bulk Dump, Tone Dump, Drum Tone Dump

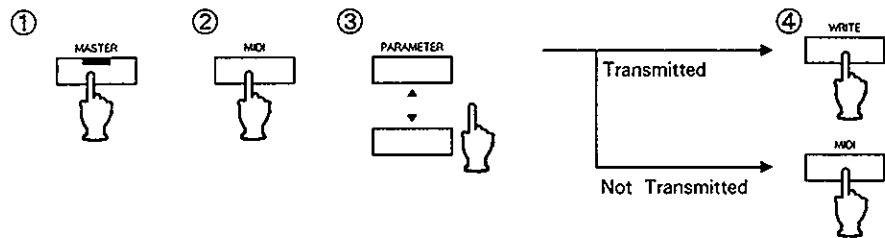

- ① Press [MASTER], and confirm that the indicator is lit.
 - ② Press [MIDI].
 - ③ Use PARAMETER [▲] [▼] to select the parameter you wish to have transmitted.
 - ④ Press [WRITE], and the JV-30's data will be transmitted.
- When the transfer has been successfully accomplished, "Completed" will be shown in the display for about one second.
Should you wish to abort the data transmission, press [MIDI].

(2) Bulk Dump (Part)

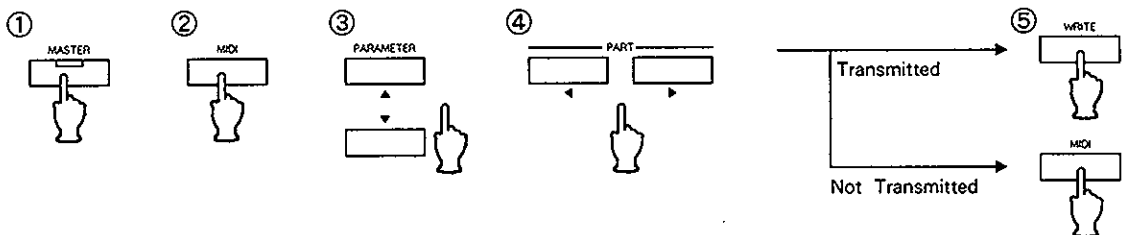

- ① Press [MASTER], and confirm that the indicator go off.
 - ② Press [MIDI].
 - ③ Use PARAMETER [▲] [▼] to select Bulk Dump (Part).
 - ④ Using PART [◀] [▶], select the Part you wish to bulk dump.
 - ⑤ Press [WRITE], and the JV-30 will transmit the Part data.
- When the transfer has been successfully accomplished, "Completed" will be shown in the display for about one second.
Should you wish to abort the data transmission, press [MIDI].

* Ordinarily, after bulk dumping data to a sequencer, you should save it onto floppy disk. However, if you use a unit such as the BOSS BL-1, the data can be stored on a memory card.

* Receiving Data

Connect the MIDI OUT on the external device to the MIDI IN on the JV-30, then set the "Exclusive Receive Switch (» p.35)" to ON.

After connection, transmit the saved data (bulk data) from the external device. The JV-30 automatically receives the data and set is reset accordingly.

Note the following:

When the JV-30 receives saved data via MIDI, the internal settings are overwritten.

Section III

APPENDIX

Concerning GS, General MIDI System



GS Format

The "GS" logo appears on the panel of the JV-30. This serves to indicate that the unit is equipped with a GS Format sound source.

The GS Format, developed by Roland, assures that all sound sources will respond in a standardized way whenever music is played using MIDI.

Thanks to this format, any song data created with any GS format sound source can be reproduced identically on any other unit with carries the GS logo.



General MIDI System

The sound source in the JV-30 conforms to General MIDI System specifications. Current recommended practice calls for conformity with the General MIDI System, since it aims at bridging the gap between manufacturers through standardization of the specifications for the MIDI functions provided by all sound sources. In fact, the Roland GS Format includes all rules set down in the General MIDI System specifications.

● Circumstances Leading to GS

The MIDI standard was created out of the need for a means to transmit performance information among electronic musical instruments, regardless of model or manufacturer. Thanks to MIDI, the realm of electronic musical instruments now enjoys a level of communicative freedom that was hitherto unimaginable. Without MIDI, automatically sequenced instrumentations, and the participation of computers in music would not have been possible.

However, certain inconveniences have become much more apparent, even while MIDI has become an indispensable part of electronic musical instruments. It sometimes seems unfortunate that MIDI has progressed this far without more of the finer details having been decided upon.

For example, MIDI defines things in terms such as "signals for changing sounds are called Program Change messages, and they should be sent in such and such a way..." However, details such as "a number something Program Change message will cause a change to a sound of this type" were never decided upon. As a result, the differences in the correspondence between the numbers and the actual sounds can sometimes become quite confusing when working with a variety of different devices. For this reason, song data that was created to be suitable for one device will often not play as expected if played by some other sound source.

The GS format has been formulated in order to alleviate such problems. Any song data created with one GS sound source in mind can be reproduced faithfully on any other GS sound source.

Troubleshooting

In cases when for some reason no sound is produced, or you think the unit is not operating as it should, first check the items below. Then, if you should still be unable to achieve normal operation, contact the store where you bought the instrument, or the nearest Roland Service Station.

No sound produced/ sound too low

- Are you sure you don't have the volume set too low?
Recheck the volume settings you have on this unit, and any amplifier or mixer you have connected.
- Can sound be heard through headphones?
If so, then you may have a cord that is damaged, or the amplifier or mixer you have connected is the source of the problem.
Check the cable(s) being used, and the equipment you have connected.
- Are you sure you do not have the Local Control MIDI parameter set to OFF?
Set it to Local ON (» p.35).
- Are you sure the value set for Master/Parts is not too low?
Recheck Master Level (» p.20) and Part Level (» p.22).
- Is it possible that the volume for Parts is being set too low as a result of Volume messages received from an external device?
Try changing the Part.
- Are you sure the Transmit channel is matched with the Receive channel used by the other device?
Refer to "Transmit Channel" (» p.34), and "Receive Channel" (» p.35).

The pitch is not right

- Could the setting for Master Tuning possibly be wrong?
Check the setting.
- Are you sure you don't have Transpose set to "ON"?
Press [TRANPOSE] to turn it OFF.
- Is the setting for Key Shift appropriate?
Check the setting (» p.23).
- Is it possible that Bender messages are being continually received?
Try moving the Bender/Modulation Lever.

Tones don't change properly

- Are you sure you do not have Local Control set to OFF?
Set it to Local ON (» p.35).
- Could you have the Tone Change Receive Switch set to OFF?
Set the Tone Change Receive Switch to ON.
- Could you possibly be in the ROM Play mode?
Press [LEVEL] and [PAN] simultaneously to exit the ROM Play mode.

Effects do not work

- Are you sure the level set for Chorus/Reverb for Master/Parts is not too low?
Recheck the settings.
- Are the indicators on relevant Effects On/Off switches (Chorus, Reverb) lighted?
Press their buttons to turn them ON.

Error Messages

When a mistake in an operational procedure has been made, or the unit is unable to carry out a procedure properly, an Error Message will appear in the display. In such cases refer to the information below, then perform the indicated remedy.

● When battery is depleted

Battery Low!

Cause: The unit's backup battery has been depleted.
Remedy: Contact your nearest Roland Service Station.

● When using other MIDI devices

MIDI Buff. Full!

Cause: An excessive amount of MIDI data was received all at once, and could not be processed properly.

Remedy: Try reducing the amount of MIDI data that is sent to the unit.

Cause: Exclusive messages could not be received correctly.

Remedy: After checking the cable and connections, and the data that is to be transmitted, try performing the procedure again.

MIDI Off Line!

Causes: The connector on a MIDI cable was disconnected, or the cable could have a bad internal connection or broken section.

Remedy: Check the MIDI cable and the connections.

Transmitted MIDI Messages

MIDI messages which can be transmitted by the JV - 30 are as follows:

	JV - 30 Action	Transmitted MIDI Message	External Device Response
Note	Press a key	Note message	Sound a note corresponding to the transmitted Note message
P.Chg	Press the Bank/Number buttons and switch between Tones	Control Change 0 + Control Change 32 (Variation Number) + Program Change message + NRPN(Tone Edit data) C.Chg 0 : 0 - 127 C.Chg 32 : 0 P.Chg : 1 - 128 NRPN	Switch to the Tone specified by the combination Control Change 0, 32 and Program Change numbers, and read in the edit data specified by NRPN
Bend	Move the Pitch Bender/Modulation Lever to change the pitch while the note is sounding	Pitch Bend messages (continuously variable) Bend : - 8192 - 0 - +8191	The currently-sounding notes will change pitch smoothly
C.Chg	Move the Bender/Modulation Lever to apply vibrato to a note	Control Change 1 (Modulation Controller Message) (continuously variable) C.Chg 1 : 0 - 127	Vibrato effect is added to the currently-sounding note
	Press the Portamento Button to add Portamento effect	Control Change 5 (Portamento Time message) (transmitted when Portamento is on) C.Chg 5 : 0 - 127	Portamento is added as defined by the Portamento Time settings on the JV-30
	Move the Pan slider to change the Pan	Control Change 10 (Pan Controller message) (continuously variable) C.Chg 10 : 0 - 127	The position of the current note in the stereo field will change
	Move the Expression slider to control the volume	Control Change 11 (Expression Controller message) (continuously variable) C.Chg 11 : 0 - 127	The current note will change volume
	Depress the Hold Pedal to sustain a note	Control Change 64 (Hold1 message) (Transmitted whether Hold is On/Off) C.Chg 64 : OFF 0 ON 127	The current note is sustained
	Press the Portamento button to turn on the Portamento effect	Control Change 65 (Portamento On/Off message) (transmitted whether Portamento is on or off) C.Chg 65 : OFF 0 ON 127	Make a smooth pitch transition from the last played note to the next note played
	Press the Solo button for solo play	Control Change 126, 127 (Mono/Poly Mode message) (transmitted whether Mono is on or off) C.Chg 126 : ON C.Chg 127 : OFF	Notes will sound one at a time
	Change a control number parameter with the control number slider	Control Change 0 - 9, 12 - 31, 64 - 95 C.Chg 0 - 9, 12 - 31, 64 - 95 Value : 0 - 127	The indicated parameter is changed

Organization of Sounds in the JV-30

The following explains the system of organization used for all sounds in the JV-30. You may have no need for reading the following, since when operating the instrument, everything concerned with sound organization is handled automatically. It is only when you wish to use an external unit to select sounds that a knowledge of the system becomes important.

[Concerning the Sound Organization]

As can be seen below, every sound is assigned a number, resulting from a combination of a Variation No. from 0-127, and a Tone No. from 1-128. The Variation Number corresponds to Control Change 0, whereas the Tone Number corresponds with Program Change. When using an external device to specify a sound, a Control Change 0 and a Program Change must be transmitted as a pair.

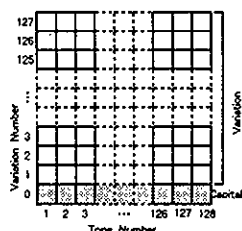

○ Capital Tones

Capital Tones are assigned to the row where the Variation Number is 0.

○ Variations

Variations are assigned to the columns containing Variation Numbers 1-127. Each Variation resides in the column corresponding to the number of the Capital Tone it is affiliated with.

The MT-32 set is assigned to Variation No. 127.

*** When using an external device to change the sound: After a Variation has been selected, and you wish to select another Variation, you only need to change the Tone Number (Program Change) to select another Variation that has the same Variation Number.**

[Concerning Sub Capitals]

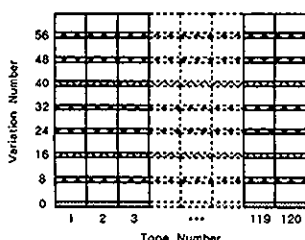

If you specify a location where no Tone is assigned when selecting a Variation, no sound will be produced. However, solely with regard to Variation Nos. 0-63, and Tone Nos. 1-120, shown left, the Tone of a Capital or Sub-Capital will be selected in its place, and sound will be produced. (See below.)

As shown at left, the Tones assigned to all Variation Numbers which are a multiple of 8 (Nos. 8, 16, 24, etc.), are designated as Sub-Capital Tones.

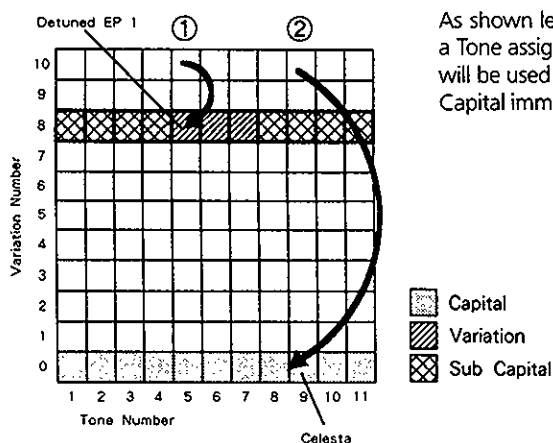

As shown left, when no Tone assignment exists: ① When there is a Tone assigned to the Sub Capital immediately below it, that Tone will be used instead. ② When there is no Tone assigned to the Sub Capital immediately below it, the Capital Tone will be used instead.

JV-30 Program Numbers

On the JV-30, Program Change data can be used to change its internal Tones, or to change Tones in an external device by means of panel operations. The Program Change data that accomplishes these tasks is communicated over the Transmit/Receive channels.

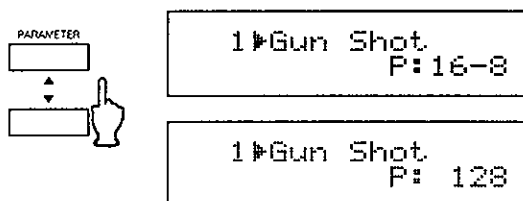

On the JV-30, a Program Change Number is allocated for each Tone. Should you wish to determine the Program Number of the currently selected Tone, press either PARAMETER [▲] or [▼] while the name of the Tone appears in the display. You can also switch between display of the Bank/Number and the Program Number.

- Transmitted Program Number when you press the JV-30's Bank/Number buttons

Number Bank	1	2	3	4	5	6	7	8
1	1	2	3	4	5	6	7	8
2	9	10	11	12	13	14	15	16
3	17	18	19	20	21	22	23	24
4	25	26	27	28	29	30	31	32
5	33	34	35	36	37	38	39	40
6	41	42	43	44	45	46	47	48
7	49	50	51	52	53	54	55	56
8	57	58	59	60	61	62	63	64
9	65	66	67	68	69	70	71	72
10	73	74	75	76	77	78	79	80
11	81	82	83	84	85	86	87	88
12	89	90	91	92	93	94	95	96
13	97	98	99	100	101	102	103	104
14	105	106	107	108	109	110	111	112
15	113	114	115	116	117	118	119	120
16	121	122	123	124	125	126	127	128

- When selecting the Drum Part

Number	Program Number
1	1
2	9
3	17
4	25
5	26
6	33
7	41
8	49
VARIATION	57
MT-32 Set	128

Whether using an external device to change this unit's Tones, or changing Tones in an external device from the JV-30, you should carefully study the Program Number Correspondence chart for the external device.

Parameter List

● Parameters Common to All Parts

Parameter Name		Value
Level		* 0-127
Tune		* 415.3-440.0-466.2
Chorus	Level	* 0-64-127
	Type	* Chorus 1/2/3/4 Feedback Chorus Flanger Short Delay Short Delay (FB)
Reverb	Level	* 0-64-127
	Type	* Room 1/2/3 Hall 1/2 Plate Delay Panning Delay
MIDI	Transmit Channel (Tx Channel)	* PART, 1-16
	Tone Change Receive Switch (Rx Tone Chg)	* OFF,ON
	GS Reset Receive Switch (Rx GS Reset)	* OFF,ON
	Exclusive Receive Switch (Rx SysEx)	* OFF,ON
	Aftertouch Receive Switch (Rx After)	* OFF,ON
	Local Control (Local)	OFF,ON
	Performance Dump Switch (Performance Dump Tx)	OFF,ON
	Device ID Number (Device ID #)	* 1-17-32
	Bulk Dump	-----
	Tone Dump	-----
Drum Tone Dump	-----	
Transpose ON/OFF	* OFF,ON	
Amount of Transposition	* -24 - 12-0 + 12	
Key Mode	* OFF, FAT, OCTAVE, DUAL, SPLIT	
Split Point	* C2-C4-C#7	

● Tone Edit Parameters

Parameter Name		Value
Vibrato	Vibrato Rate	- 50-0 + 50
	Vibrato Depth	- 50-0 + 50
	Vibrato Delay	- 50-0 + 50
Filter	Cutoff Frequency	- 50-0 + 16
	Resonance	- 50-0 + 50
Envelope	Attack Time	- 50-0 + 50
	Decay Time	- 50-0 + 50
	Release Time	- 50-0 + 50

● Parameters for Individual Parts

Parameter		Value
Level	*	0-108-127 (100)
Pan	*	L63-0-R63,RND
Chorus Send Depth	*	0-40-127 (0)
Reverb Send Depth	*	0-64-127 (40)
MIDI	Receive Channel (Rx Channel)	* OFF, 1-16
	Bulk Dump	-----
Control	Bend Range	* 0-2-24
	Modulation Depth	* 0-10-127
	Key Shift	* -24-0-+24
	Velocity Sens Depth	* 0-64-127
	Velocity Sens Offset	* 0-64-127
	Voice Reserve	* 0~24
Tone Select	*	-----
Effect ON/OFF	Chorus	* OFF, ON
	Reverb	* OFF, ON
Solo ON/OFF	*	OFF, ON
Portamento ON/OFF	*	OFF, ON
Portamento Time	*	0-30-127 (0)

● Drum Tone Edit Parameters

Parameter Name	Value
Pitch	-24-0-+24
Level	0-127
Pan	L63-0-R63, RND
Reverb Depth	0-127

● MIDI Controller Features Parameters

Parameter Name		Value
Expression		0-127
Pan		0-127
Control Number	Control Number	0-9, 12-31, 64-95
	Value	0-127

Bold : Factory Preset Setting

***** : Parameters which can be recorded as part of a performance

() : GS Default Setting

Blank : Same as the Factory Preset setting except " ()".

TONE TABLE

	#	PC#	CC0#	Tone name	V	Recommended sound range
BANK1 : Piano	1	1	0	Piano 1	1	A0 (21) — C8 (108)
	2	2	0	Piano 2	1	
	3	3	0	Piano 3	1	
	4	4	0	Honky-tonk	2	C2 (36) — C7 (96)
	5	5	0	E. Piano 1	1	
			8	Detuned EP 1	2	
	6	6	0	E. Piano 2	1	
			8	Detuned EP 2	2	
7	7	0	Harpsichord	1	F2 (41) — F6 (89)	
		8	Coupled Hps.	2		
8	8	0	Clav.	1	C2 (36) — C7 (96)	
BANK2 : Chromatic Percussion	1	9	0	Celesta	1	C4 (60) — C8 (108)
	2	10	0	Glockenspiel	1	C5 (72) — C8 (108)
	3	11	0	Music Box	1	C4 (60) — C6 (84)
	4	12	0	Vibraphone	1	F3 (53) — F6 (89)
	5	13	0	Marimba	1	C3 (48) — C6 (84)
	6	14	0	Xylophone	1	F4 (65) — C7 (96)
	7	15	0	Tubular-bell	1	C4 (60) — F5 (77)
			8	Church Bell	1	
8	16	0	Santur	1	C4 (60) — C6 (84)	
BANK3 : Organ	1	17	0	Organ 1	1	C2 (36) — C7 (96)
			8	Detuned Or. 1	2	
	2	18	0	Organ 2	1	
			8	Detuned Or. 2	2	
	3	19	0	Organ 3	2	A0 (21) — C8 (108)
	4	20	0	Church Org. 1	1	
			8	Church Org. 2	2	
	5	21	0	Reed Organ	1	C2 (36) — C7 (96)
	6	22	0	Accordion Fr	2	F3 (53) — F6 (89)
			8	Accordion It	2	
	7	23	0	Harmonica	1	C4 (60) — C6 (84)
	8	24	0	Bandneon	2	F3 (53) — F6 (89)

	#	PC#	CC0#	Tone name	V	Recommended sound range
BANK4 : Guitar	1	25	0	Nylon-str. Gt.	1	E2 (40) — C6 (84)
			8	Ukulele	1	A3 (57) — B5 (83)
	2	26	0	Steel-str. Gt.	1	E2 (40) — C6 (84)
			8	12-str. Gt.	2	
			16	Mandolin	1	G3 (55) — E6 (88)
	3	27	0	Jazz Gt.	1	E2 (40) — D6 (86)
			8	Hawaiian Gt.	1	
	4	28	0	Clean Gt.	1	
			8	Chorus Gt.	2	
	5	29	0	Muted Gt.	1	
			8	Funk Gt.	1	
	6	30	0	Overdrive Gt.	1	
	7	31	0	Distortion Gt	1	
			8	Feedback Gt.	2	
	8	32	0	Gt. Harmonics	1	
			8	Gt. Feedback	1	
BANK5 : Bass	1	33	0	Acoustic Bs.	1	E1 (28) — G3 (55)
	2	34	0	Fingered Bs.	1	
	3	35	0	Picked Bs.	1	
	4	36	0	Fretless Bs.	1	
	5	37	0	Slap Bass 1	1	
	6	38	0	Slap Bass 2	1	
	7	39	0	Synth Bass 1	1	
			8	Synth Bass 3	1	
8	40	0	Synth Bass 2	2		
		8	Synth Bass 4	2		

- # : Number
 PC # : Program number
 CC0 # : Value of control number 0
 (GS bank select number)
 V : Number of voices
 Recommended sound range : The recommended sound range does not indicate the limit of sound production. The actual playable range extends beyond the recommended sound range.

TONE TABLE

	#	PC#	CC0#	Tone Name	Voice
BANK5: Bass	1	33	0	Acoustic Bs.	1
	2	34	0	Fingered Bs.	1
	3	35	0	Picked Bs.	1
	4	36	0	Fretless Bs.	1
	5	37	0	Slap Bass 1	1
	6	38	0	Slap Bass 2	1
	7	39	0	Synth Bass 1	1
			1	SynthBass101	1
8			Synth Bass 3	1	
8	40	0	Synth Bass 2	2	
		8	Synth Bass 4	2	
		16	Rubber Bass	2	
BANK6: Strings/Orchestra	1	41	0	Violin	1
			8	Slow Violin	1
	2	42	0	Viola	1
	3	43	0	Cello	1
	4	44	0	Contrabass	1
	5	45	0	Tremolo Str	1
	6	46	0	PizzicatoStr	1
	7	47	0	Harp	1
8	48	0	Timpani	1	
BANK7: Ensemble	1	49	0	Strings	1
			8	Orchestra	2
	2	50	0	Slow Strings	1
	3	51	0	Syn.Strings1	1
			8	Syn.Strings3	2
	4	52	0	Syn.Strings2	2
	5	53	0	Choir Aahs	1
			32	Choir Aahs 2	1
6	54	0	Voice Oohs	1	
7	55	0	SynVox	1	
8	56	0	OrchestraHit	2	

	#	PC#	CC0#	Tone Name	Voice
BANK8: Brass	1	57	0	Trumpet	1
	2	58	0	Trombone	1
			1	Trombone 2	2
	3	59	0	Tuba	1
	4	60	0	MutedTrumpet	1
	5	61	0	French Horn	2
			1	Fr.Horn 2	2
	6	62	0	Brass 1	1
8			Brass 2	2	
7	63	0	Synth Brass1	2	
		8	Synth Brass3	2	
		16	AnalogBrass1	2	
		0	Synth Brass2	2	
8	64	8	Synth Brass4	1	
		16	AnalogBrass2	2	
		0	Synth Brass2	2	
		8	Synth Brass4	1	
BANK9: Reed	1	65	0	Soprano Sax	1
	2	66	0	Alto Sax	1
	3	67	0	Tenor Sax	1
	4	68	0	Baritone Sax	1
	5	69	0	Oboe	1
	6	70	0	English Horn	1
	7	71	0	Bassoon	1
	8	72	0	Clarinet	1
BANK10: Pipe	1	73	0	Piccolo	1
	2	74	0	Flute	1
	3	75	0	Recorder	1
	4	76	0	Pan Flute	1
	5	77	0	Bottle Blow	2
	6	78	0	Shakuhachi	2
	7	79	0	Whistle	1
	8	80	0	Ocarina	1
BANK11: Synth Lead	1	81	0	Square Wave	2
			1	Square	1
			8	Sine Wave	1
	2	82	0	Saw Wave	2
			1	Saw	1
			8	Doctor Solo	2
	3	83	0	Syn.Calliope	2
	4	84	0	Chiffer Lead	2
5	85	0	Charang	2	
6	86	0	Solo Vox	2	
7	87	0	5th Saw Wave	2	
8	88	0	Bass & Lead	2	

: Number
 PC # : Program number
 CC0# : Value of control number 0 (GS Bank select number)
 Voice : Number of voices

STONE TABLE

	#	PC#	CC0#	Tone name	V
BANK13 : Synth SFX	1	97	0	Ice Rain	2
	2	98	0	Soundtrack	2
	3	99	0	Crystal	2
	4	100	0	Atmosphere	2
	5	101	0	Brightness	2
	6	102	0	Goblin	2
	7	103	0	Echo Drops	1
	8	104	0	Star Theme	2
BANK14 : Ethnic	1	105	0	Sitar	1
	2	106	0	Banjo	1
	3	107	0	Shamisen	1
	4	108	0	Koto	1
			8	Taisho Koto	2
	5	109	0	Kalimba	1
	6	110	0	Bag Pipe	1
	7	111	0	Fiddle	1
BANK15 : Percussive	8	112	0	Shannai	1
	1	113	0	Tinkle Bell	1
	2	114	0	Agogo	1
	3	115	0	Steel Drums	1
	4	116	0	Woodblock	* 1
			8	Castanets	* 1
	5	117	0	Taiko	* 1
			8	Concert BD	* 1
	6	118	0	Melo Tom 1	* 1
			8	Melo Tom 2	* 1
	7	119	0	Synth Drum	* 1
			8	808 Tom	* 1
8	120	0	Reverse Cym.	* 2	

: Number
 PC # : Program number
 CC0 # : Value of control number 0
 (GS bank select number)
 V : Number of voices
 * : All tones marked by an * have an unreliable pitch. Please use a key around C4 (Key # 60).
 The unmarked tones use temperament and pitch of A4 (Key # 69) is 440Hz.

	#	PC#	CC0#	Tone name	V
BANK16 : SFX	1	121	0	Gt. FretNoise	* 1
			1	Gt. Cut Noise	* 1
			2	String Slap	* 1
	2	122	0	Breath Noise	2
			1	Fl. Key Click	* 1
	3	123	0	Seashore	* 1
			1	Rain	* 2
			2	Thunder	* 1
			3	Wind	* 1
			4	Stream	* 2
	4	124	0	Bird	* 2
			1	Dog	* 1
5	125	2	Horse-Gallop	* 1	
		0	Telephone 1	* 1	
		1	Telephone 2	* 1	
		2	Door Creaking	* 1	
		3	Door	* 1	
6	126	4	Scratch	* 1	
		5	Windchime	* 2	
		0	Helicopter	* 1	
		1	Car-Engine	* 1	
		2	Car-Stop	* 1	
		3	Car-Pass	* 1	
		4	Car-Crash	* 2	
		5	Siren	* 1	
		6	Train	* 1	
7	Jetplane	* 2			
7	127	8	Starship	* 2	
		9	Burst Noise	* 2	
		0	Applause	* 2	
		1	Laughing	* 1	
		2	Screaming	* 1	
8	128	3	Punch	* 1	
		4	Heart Beat	* 1	
		5	Footsteps	* 1	
		0	Gun Shot	* 1	
		1	Machine Gun	* 1	
		2	Lasergun	* 1	
		3	Explosion	* 2	

TONE TABLE

● MT-32 set (CC0 # : 127)

PC #	Tone name	V	PC #	Tone name	V	PC #	Tone name	V	PC #	Tone name	V
1	Acou Piano 1	1	33	Fantasy	2	65	Acou Bass 1	1	97	Brs Sect 2	2
2	Acou Piano 2	1	34	Harmo Pan	2	66	Acou Bass 2	1	98	Vibe 1	1
3	Acou Piano 3	1	35	Chorale	1	67	Elec Bass 1	1	99	Vibe 2	1
4	Elec Piano 1	1	36	Glasses	2	68	Elec Bass 2	1	100	Syn Mallet	1
5	Elec Piano 2	1	37	Soundtrack	2	69	Slap Bass 1	1	101	Windbell	2
6	Elec Piano 3	1	38	Atmosphere	2	70	Slap Bass 2	1	102	Glock	1
7	Elec Piano 4	1	39	Warm Bell	2	71	Fretless 1	1	103	Tube Bell	1
8	Honkytonk	2	40	Funny Vox	1	72	Fretless 2	1	104	Xylophone	1
9	Elec Org 1	1	41	Echo Bell	2	73	Flute 1	1	105	Marimba	1
10	Elec Org 2	2	42	Ice Rain	2	74	Flute 2	1	106	Koto	1
11	Elec Org 3	1	43	Oboe 2001	2	75	Piccolo 1	1	107	Sho	2
12	Elec Org 4	1	44	Echo Pan	2	76	Piccolo 2	2	108	Shakuhachi	2
13	Pipe Org 1	2	45	Doctor Solo	2	77	Recorder	1	109	Whistle 1	2
14	Pipe Org 2	2	46	School Daze	1	78	Pan Pipes	1	110	Whistle 2	1
15	Pipe Org 3	2	47	Bellsinger	1	79	Sax 1	1	111	Bottleblow	2
16	Accordion	2	48	Square Wave	2	80	Sax 2	1	112	Breathpipe	1
17	Harpsi 1	1	49	Str Sect 1	1	81	Sax 3	1	113	Timpani	1
18	Harpsi 2	2	50	Str Sect 2	1	82	Sax 4	1	114	Melodic Tom	1
19	Harpsi 3	1	51	Str Sect 3	1	83	Clarinet 1	1	115	Deep Snare	1
20	Clavi 1	1	52	Pizzicato	1	84	Clarinet 2	1	116	Elec Perc 1	1
21	Clavi 2	1	53	Violin 1	1	85	Oboe	1	117	Elec Perc 2	1
22	Clavi 3	1	54	Violin 2	1	86	Engl Horn	1	118	Taiko	1
23	Celesta 1	1	55	Cello 1	1	87	Bassoon	1	119	Taiko Rim	1
24	Celesta 2	1	56	Cello 2	1	88	Harmonica	1	120	Cymbal	1
25	Syn Brass 1	2	57	Contrabass	1	89	Trumpet 1	1	121	Castanets	1
26	Syn Brass 2	2	58	Harp 1	1	90	Trumpet 2	1	122	Triangle	1
27	Syn Brass 3	2	59	Harp 2	1	91	Trombone 1	2	123	Orche Hit	1
28	Syn Brass 4	2	60	Guitar 1	1	92	Trombone 2	2	124	Telephone	1
29	Syn Bass 1	1	61	Guitar 2	1	93	Fr Horn 1	2	125	Bird Tweet	1
30	Syn Bass 2	2	62	Elec Gtr 1	1	94	Fr Horn 2	2	126	One Note Jam	1
31	Syn Bass 3	2	63	Elec Gtr 2	1	95	Tuba	1	127	Water Bell	2
32	Syn Bass 4	1	64	Sitar	2	96	Brs Sect 1	1	128	Jungle Tune	2

CC0 # : Value of control number 0
(GS bank select number)

PC # : Program number

V : Number of voices

- ※ 127 of control number 0 is set to the same sound arrangement of the MT-32 (Roland Multi Timbre Sound Module). But the setting of the pitch bend range, modulation depth, etc., are different from that of MT-32. Pan directions are reversed from an actual MT-32, so to rectify this, reverse the L/R connections of the Audio Output jacks.
- ※ If exclusive messages of the MT-32 are received by the JV-30, the settings of the latter will not be changed.

DRUM SET TABLE

Note number	PC # 1 : STANDARD Set. PC # 33 : JAZZ Set	PC # 9 : ROOM Set	PC # 17 : POWER Set
27	High - O		
28	Slap		
29	Scratch Push [EXC1]		
30	Scratch Pull [EXC1]		
31	Sticks		
32	Square Click		
33	Metronome Click (Mtrnm. Click)		
34	Metronome Bell (Mtrnm. Bell)		
35	Kick Drum 2 (Kick 2)		
36	Kick Drum 1 (Kick 1)		MONDO Kick (Mondo Kick)
37	Side Stick		
38	Snare Drum 1 (Fat Snare)		Gated SD (Reverb Snare)
39	Hand Clap		
40	Snare Drum 2 (Tight Snare)		
41	Low Tom 2 (Tom)	Room Low Tom 2 (Melo. Tom 2)	Room Low Tom 2 (Melo. Tom 2)
42	Closed Hi - Hat (Close Hi Hat) [EXC2]		
43	Low Tom 1 (Tom)	Room Low Tom 1 (Melo. Tom 2)	Room Low Tom 1 (Melo. Tom 2)
44	Pedal Hi - Hat (Pedal Hi Hat) [EXC2]		
45	Mid Tom 2 (Tom)	Room Mid Tom 2 (Melo. Tom 2)	Room Mid Tom 2 (Melo. Tom 2)
46	Open Hi - Hat (Open Hi Hat) [EXC2]		
47	Mid Tom 1 (Tom)	Room Mid Tom 1 (Melo. Tom 2)	Room Mid Tom 1 (Melo. Tom 2)
48	High Tom 2 (Tom)	Room Hi Tom 2 (Melo. Tom 2)	Room Hi Tom 2 (Melo. Tom 2)
49	Crash Cymbal 1 (Crash Cymbal)		
50	High Tom 1 (Tom)	Room Hi Tom 1 (Melo. Tom 2)	Room Hi Tom 1 (Melo. Tom 2)
51	Ride Cymbal 1 (Ride Cymbal)		
52	Chinese Cymbal (China Cymbal)		
53	Ride Bell		
54	Tambourine		
55	Splash Cymbal (Crash Cymbal)		
56	Cowbell		
57	Crash Cymbal 2 (Crash Cymbal)		
58	Vibra - slap (Vibraslap)		
59	Ride Cymbal 2 (Ride Cymbal)		
60	High Bongo		
61	Low Bongo		
62	Mute High Conga (Mute Conga)		
63	Open High Conga (Conga)		
64	Low Conga (Conga)		
65	High Timbale (Timbales)		
66	Low Timbale (Timbales)		
67	High Agogo (Agogo)		
68	Low Agogo (Agogo)		
69	Cabasa		
70	Maracas		
71	Short Hi Whistle (ShortWhistle) [EXC3]		
72	Long Low Whistle (Long Whistle) [EXC3]		
73	Short Guiro [EXC4]		
74	Long Guiro [EXC4]		
75	Cleves		
76	High Wood Block (Woodblock)		
77	Low Wood Block (Woodblock)		
78	Mute Cuica [EXC5]		
79	Open Cuica [EXC5]		
80	Mute Triangle (Mute Triangl) [EXC6]		
81	Open Triangle (Open Triangl) [EXC6]		
82	Shaker (808 Maracas)		
83	Jingle Bell		
84	Belltire		
85	Castanets		
86	Mute Surdo [EXC7]		
87	Open Surdo [EXC7]		
88	---		

PC # : Program number

★ : Tones which are created by using two voices.
(All other tones are created by one voice.)

Blank : Same as the percussion sound of "STANDARD"

----- : No sound

[EXC] : Percussion sound of the same number will not be heard at the same time.

DRUM SET TABLE

Note number	PC# 25 : ELECTRONIC Set	PC# 26 : TR - 808 Set	PC# 41 : BRUSH Set	PC# 49 : ORCHESTRA Set
28	★ 27			Closed Hi - Hat (Close Hi Hat) [EXC1]
29				Pedal Hi - Hat (Close Pedal Hat) [EXC1]
30				Open Hi - Hat (Open Hi Hat) [EXC1]
31				Ride Cymbal
32				
33				
34				
35				Concert BD 2 (Kick 2)
36	Elec BD (Elec.Kick)	808 Bass Drum (808 Kick)		Concert BD 1 (Concert BD)
37		808 Rim Shot (808 Rimshot)		
38	Elec SD (Elec Snare)	808 Snare Drum (808 Snare)	Brush Tap	Concert SD 1 (ConcertSnare)
39			Brush Slop	Castanets
40	Gated SD (Reverb Snare)		Brush Swirl	Concert SD 2 (ConcertSnare)
41	Elec Low Tom 2 (Synth Drum)	808 Low Tom 2 (808 Tom)		Timpani F (Timpani)
42		808 CHH (808 Hi Hat C) [EXC1]		Timpani F # (Timpani)
43	Elec Low Tom 1 (Synth Drum)	808 Low Tom 1 (808 Tom)		Timpani G (Timpani)
44		808 CHH (808 Hi Hat C) [EXC1]		Timpani G # (Timpani)
45	Elec Mid Tom 2 (Synth Drum)	808 Mid Tom 2 (808 Tom)		Timpani A (Timpani)
46		808 OHH (808 Hi Hat O) [EXC1]		Timpani A # (Timpani)
47	Elec Mid Tom 1 (Synth Drum)	808 Mid Tom 1 (808 Tom)		Timpani B (Timpani)
48	Elec Hi Tom 2 (Synth Drum)	808 Hi Tom 2 (808 Tom)		Timpani c (Timpani)
49		808 Cymbal (808 Crash)		Timpani c # (Timpani)
50	Elec Hi Tom 1 (Synth Drum)	808 Hi Tom 1 (808 Tom)		Timpani d (Timpani)
51				Timpani d # (Timpani)
52	Reverse Cymbal (Reverse Cym.)			Timpani e (Timpani)
53				Timpani f (Timpani)
54				
55				
56		808 Cowbell		
57				
58				
59				Concert Cymbal 1 (Concert Cym.)
60				
61				
62		808 High Conga (808 Conga)		
63		808 Mid Conga (808 Conga)		
64		808 Low Conga (808 Conga)		
65				
66				
67				
68				
69				
70		808 Maracas		
71				
72				
73				
74				
75		808 Claves		
76				
77				
78				
79				
80				
81				
82				
83				
84				
85				
86				
87				
88	---			Applause ★

PC# : Program number

★ : Tones which are created by using two voices.
(All other tones are created by one voice.)

Blank : Same as the percussion sound of "STANDARD"

----- : No sound

[EXC] : Percussion sound of the same number will not be heard at the same time.

DRUM SET TABLE

● SFX set (Program number 57)

Note number	PC#57:SFX Set
39	High O
40	Slap
41	Scratch Push
42	Scratch Pull
43	Sticks
44	Square Click
45	Metronome Click (Mtrm. Click)
46	Metronome Bell (Mtrm. Bell)
47	Guitar sliding finger(Gt. FretNoise)
48	Guitar cutting noise (down) (Gt.Cut Noise)
49	Guitar cutting noise (up) (Gt. CutNoise)
50	String slap of double bass (String Slap)
51	Fl. Key Click
52	Laughing
53	Screaming
54	Punch
55	Heart Beat
56	Footsteps1
57	Footsteps2
58	Applause ★
59	Door Creaking
60	Door
61	Scratch
62	Windchime ★
63	Car-Engine
64	Car-Stop
65	Car-Pass
66	Car-Crash ★
67	Siren
68	Train
69	Jetplane ★
70	Helicopter
71	Starship ★
72	Gun Shot
73	Machine Gun
74	Lasergun
75	Explosion ★
76	Dog
77	Horse-Gallop
78	Birds ★
79	Rain ★
80	Thunder
81	Wind
82	Seashore
83	Stream ★
84	Bubble ★

- ★ : Tones which are created by using two voices.
(All other tones are created by one voice.)
- : No sound
- [EXC] : Percussion sounds of the same number cannot be heard at the same time.

※ The CM-64/32L set is the MT-32 drum set with SFX sounds added to it.

● CM64/32L set (Programnumber128)

Note number	PC#128:CM-64/32L Set
34	-----
35	Acoustic Bass Drum
36	Acoustic Bass Drum
37	Rim Shot
38	Acoustic Snare Drum
39	Hand Clap
40	Electronic Snare Drum
41	Acoustic Low Tom
42	Closed High Hat [EXC1]
43	Acoustic Low Tom
44	Open High Hat 2
45	Acoustic Middle Tom
46	Open High Hat 1 [EXC1]
47	Acoustic Middle Tom
48	Acoustic High Tom
49	Crash Cymbal
50	Acoustic High Tom
51	Ride Cymbal
52	-----
53	-----
54	Tambourine
55	-----
56	Cowbell
57	-----
58	-----
59	-----
60	High Bongo
61	Low Bongo
62	Mute High Conga
63	High Conga
64	Low Conga
65	High Timbale
66	Low Timbale
67	High Agogo
68	Low Agogo
69	Cabasa
70	Maracas
71	Short Whistle
72	Long Whistle
73	Quijada
74	-----
75	Claves
76	Laughing
77	Screaming
78	Punch
79	Heartbeat
80	Footsteps 1
81	Footsteps 2
82	Applause ★
83	Creaking
84	Door
85	Scratch
86	Windchime ★
87	Engine
88	Car-Stop
89	Car-Pass
90	Crash ★
91	Siren
92	Train
93	Jet
94	Helicopter
95	Starship ★
96	Pistol
97	Machine Gun
98	Lasergun
99	Explosion ★
100	Dog
101	Horse-Gallop
102	Birds ★
103	Rain ★
104	Thunder
105	Wind
106	Waves
107	Stream ★
108	Bubble ★

- * The size of the requested data does not indicate the number of bytes that will make up a DT1 message, but represents the address fields where the requested data resides.
- * Some models are subject to limitations in data format used for a single transaction. Requested data, for example, may have a limit in length or must be divided into predetermined address fields before it is exchanged across the interface.
- * The same number of bytes comprises address and size data, which, however, vary with the Model-ID.
- * The error checking process uses a checksum that provides a bit pattern where the least significant 7 bits are zero when values for an address, size, and that checksum are summed.

= Data set 1 : DT1 (12H)

This message corresponds to the actual data transfer process. Because every byte in the data is assigned a unique address, a DT1 message can convey the starting address of one or more data as well as a series of data formatted in an address-dependent order.

The MIDI standards inhibit non-real time messages from interrupting an exclusive one. This fact is inconvenient for the devices that support a "soft-through" mechanism. To maintain compatibility with such devices, Roland has limited the DT1 to 256 bytes so that an excessively long message is sent out in separate segments.

Byte	Description
FOH	Exclusive
41H	Manufacturer ID (Roland)
DEV	Device ID
MDL	Model ID
12H	Command ID
aaH	Address MSB
⋮	⋮
⋮	LSB
ddH	Data
⋮	⋮
sum	Check sum
F7H	End of exclusive

- * A DT1 message is capable of providing only the valid data among those specified by an RQ1 message.
- * Some models are subject to limitations in data format used for a single transaction. Requested data, for example, may have a limit in length or must be divided into predetermined address fields before it is exchanged across the interface.
- * The number of bytes comprising address data varies from one Model-ID to another.
- * The error checking process uses a checksum that provides a bit pattern where the least significant 7 bits are zero when values for an address, size, and that checksum are summed.

= Example of Message Transactions

- Device A sending data to Device B
Transfer of a DT1 message is all that takes place.

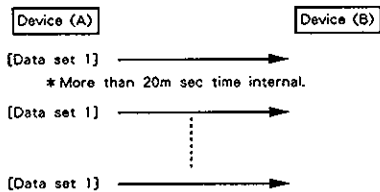

- Device B requesting data from Device A
Device B sends an RQ1 message to Device A. Checking the message, Device A sends a DT1 message back to Device B.

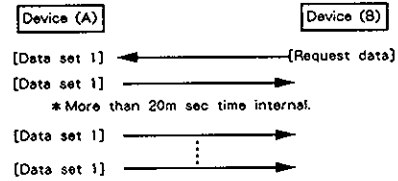

16 PART MULTI TIMBRAL SYNTHESIZER
JV-30 MIDI IMPLEMENTATION

Date : Jan. 6 1992
Version : 1.01

1. Receive Data

■ Channel Voice Message

● Note off

Status	Second	Third
BnH	kkH	vvH
9nH	kkH	00H

n = MIDI channel number : 0H - FH (ch.1 - ch.16)
 kk = Note number : 00H - 7FH (0 - 127)
 vv = Velocity : 00H - 7FH (0 - 127)

*Ignored when "Rx.Note message = OFF".
 *In the drum part, recognized when "Rx.Note off = ON" at each instrument.
 *Velocity is ignored.

● Note on

Status	Second	Third
9nH	kkH	vvH

n = MIDI channel number : 0H - FH (ch.1 - ch.16)
 kk = Note number : 00H - 7FH (0 - 127)
 vv = Velocity : 01H - 7FH (1 - 127)

*Ignored when "Rx.Note message = OFF".
 *In the drum part, ignored when "Rx.Note on = OFF" at each tone.

● Polyphonic key pressure

Status	Second	Third
AnH	kkH	vvH

n = MIDI channel number : 0H - FH (ch.1 - ch.16)
 kk = Note number : 00H - 7FH (0 - 127)
 vv = Value : 00H - 7FH (0 - 127)

*Ignored when "Rx.Polyphonic key pressure = OFF".
 *Effect to the parameter set on "PA1 controller function".
 No initial setting available.

● Control change

*Ignore all control change messages except channel mode messages when "Rx.Control change = OFF".

○ Bank select

Status	Second	Third
BnH	00H	mmH
BnH	20H	llH

n = MIDI channel number : 0H - FH (ch.1 - ch.16)
 mm, ll = Bank number : 00H, 00H - 7FH, 7FH (bank.1 - bank.16384)

*The LSB 7-bit is ignored (value = 00).
 *"Bank select" is suspended until receiving "Program change".
 To select a timbre of another bank, you have to send Bank select (mm, ll) before sending the Program change.
 *The "Variation number" of the JV-30 is defined as the decimal number of the value of MSB (Control change number 00H) of the Bank select.

○ Modulation

Status	Second	Third
BnH	01H	vvH

n = MIDI channel number : 0H - FH (ch.1 - ch.16)
 vv = Modulation depth : 00H - 7FH (0 - 127)

*Ignored when "Rx.Modulation = OFF".
 *Effect to the parameter set on "MOD controller function".
 The default setting is pitch modulation.

○ Portamento time

Status	Second	Third
BnH	05H	vvH

n = MIDI channel number : 0H - FH (ch.1 - ch.16)
 vv = Portamento time : 00H - 7FH (0 - 127)

*The Portamento time value changes the rate of pitch change at portamento on.

○ Data entry

Status	Second	Third
BnH	06H	mmH
BnH	26H	llH

n = MIDI channel number : 0H - FH (ch.1 - ch.16)
 mm, ll = Value of the parameter specified with RPN and/or NRPN

○ Volume

Status	Second	Third
BnH	07H	vvH

n = MIDI channel number : 0H - FH (ch.1 - ch.16)
 vv = Volume : 00H - 7FH (0 - 127)

*Ignored when "Rx.Volume = OFF".

○ Panpot

Status	Second	Third
BnH	0AH	vvH

n = MIDI channel number : 0H - FH (ch.1 - ch.16)
 vv = Panpot : 00H - 40H - 7FH (Left - Center - Right)

*Resolution of panpot is approx. 7-bit (127 steps).
 *Ignored when "Rx.Panpot = OFF".

○ Expression

Status	Second	Third
BnH	0BH	vvH

n = MIDI channel number : 0H - FH (ch.1 - ch.16)
 vv = Expression : 00H - 7FH (0 - 127)

*Ignored when "Rx.Expression = OFF".

○ Hold1

Status	Second	Third
BnH	40H	vvH

n = MIDI channel number : 0H - FH (ch.1 - ch.16)
 vv = Control Value : 00H - 7FH (0 - 127)
 0 - 63 = OFF, 64 - 127 = ON

*Ignored when "Rx.Hold1 = OFF".

○ Portamento

Status	Second	Third
BnH	41H	vvH

n = MIDI channel number : 0H - FH (ch.1 - ch.16)
 vv = Control Value : 00H - 7FH (0 - 127)
 0 - 63 = OFF, 64 - 127 = ON

*Ignored when "Rx.Portamento = OFF".

○ Sostenuto

Status	Second	Third
BnH	42H	vvH

n = MIDI channel number : 0H - FH (ch.1 - ch.16)
 vv = Control Value : 00H - 7FH (0 - 127)
 0 - 63 = OFF, 64 - 127 = ON

*Ignored when "Rx.Sostenuto = OFF".

○ Soft

Status	Second	Third
BnH	43H	vvH

n = MIDI channel number : 0H - FH (ch.1 - ch.16)
 vv = Control Value : 00H - 7FH (0 - 127)
 0 - 63 = OFF, 64 - 127 = ON

*Ignored when "Rx.Soft = OFF".

○ Effect1 depth (Reverb send level (depth))

Status	Second	Third
BnH	5BH	vvH

n = MIDI channel number : 0H - FH (ch.1 - ch.16)
 vv = Control Value : 00H - 7FH (0 - 127)

○ Effect3 depth (Chorus send level (depth))

Status	Second	Third
8nH	5DH	vvH

n = MIDI channel number : 0H - FH (ch.1 - ch.16)
 vv = Control Value : 00H - 7FH (0 - 127)

○ NRPN MSB/LSB

Status	Second	Third
8nH	63H	mmH
8nH	62H	llH

n = MIDI channel number : 0H - FH (ch.1 - ch.16)
 mm = MSB of the specified parameter by NRPN
 ll = LSB of the specified parameter by NRPN

* Recognized when "Rx.NRPN = ON". "Rx.RPN" is set to OFF by power on reset or receiving "Turn General MIDI System On" (F0 7E 7F 09 01 F7), and it is set to ON by "GS RESET" (F0 41 10 42 12 40 00 7F 00 41 F7).
 * The value set by NRPN won't be reset by receiving new Program Change messages.

** NRPN **

NRPN (Non Registered Parameter Number) is an expanded control change message. Each function of an NRPN is described by the individual manufactures. Set NRPN MSB/LSB before sending data entry.

You can change the value of several sound parameters. There are relative change (from preset) parameters and absolute change parameters. The relative change parameters may have limits on the effect (depend upon the timbres or Models) even if the value is between 0EH - 72H. The NRPN parameters of JV-30 are as shown below:

NRPN	Data entry	Description
MSB LSB	MSB	
01H 08H	mmH	Vibrato rate relative change on specified channel mm : 0EH - 40H - 72H (-50 - 0 - +50)
01H 09H	mmH	Vibrato depth relative change on specified channel mm : 0EH - 40H - 72H (-50 - 0 - +50)
01H 0AH	mmH	Vibrato delay relative change on specified channel mm : 0EH - 40H - 72H (-50 - 0 - +50)
01H 20H	mmH	TVF cutoff frequency relative change on specified channel mm : 0EH - 40H - 72H (-50 - 0 - +50)
01H 21H	mmH	TVF resonance relative change on specified channel mm : 0EH - 40H - 72H (-50 - 0 - +50)
01H 63H	mmH	TVF & TVA Env. Attack time relative change on specified channel mm : 0EH - 40H - 72H (-50 - 0 - +50)
01H 64H	mmH	TVF & TVA Env. Decay time relative change on specified channel mm : 0EH - 40H - 72H (-50 - 0 - +50)
01H 66H	mmH	TVF & TVA Env. Release time relative change on specified channel mm : 0EH - 40H - 72H (-50 - 0 - +50)
18H rrH	mmH	Pitch coarse of drum tone relative change on specified drum tone rr : note number of drum tone mm : 00H - 40H - 7FH (-64 - 0 - +63)
1AH rrH	mmH	TVA level of drum tone absolute change on specified drum tone rr : note number of drum tone mm : 00H - 7FH (zero - maximum)
1CH rrH	mmH	Panpot of drum tone absolute change on specified drum tone rr : note number of drum tone mm : 00H, 01H - 40H - 7FH (Random, Left - Center - Right)
1DH rrH	mmH	Reverb send level of drum tone absolute change on specified drum tone rr : note number of drum tone mm : 00H - 7FH (zero - maximum)
1EH rrH	mmH	Chorus send level of drum tone absolute change on specified drum tone rr : note number of drum tone mm : 00H - 7FH (zero - maximum)

* Data entry LSB is ignored.
 * The effective range of value for these parameters may more narrow than the range shown above depend on the timbres.

○ RPN MSB/LSB

Status	Second	Third
8nH	65H	mmH
8nH	64H	llH

n = MIDI channel number : 0H - FH (ch.1 - ch.16)
 mm = MSB of the specified parameter by RPN
 ll = MSB of the specified parameter by RPN
 * Ignored when "Rx.RPN = OFF".

** RPN **

RPN (Registered Parameter Number) is the expanded control change message. Each function of RPN is described by MIDI.

You can change the value of RPN parameters. First, set RPN MSB/LSB before sending data entry.

JV-30 can receive Pitch bend sensitivity (RPN # 0), Master fine tuning (RPN # 1), Master coarse tuning (RPN # 2) and RPN reset (RPN # 16383).

RPN	Data entry	Description
MSB LSB	MSB LSB	
00H 00H	mmH ---	Pitch bend sensitivity mm : 00H - 18H (0 - 24 semitone) ll : ignored (Up to 2 octaves, power on default is two semitones)
00H 01H	mmH llH	Master fine tuning mm, ll : 00H, 00H - 40H, 00H - 7FH, 7FH (-8192 * 100 / 8192 - 0 - +8191 * 100 / 8192 cent)
00H 02H	mmH ---	Master coarse tuning mm : 28H - 40H - 58H (-24 - 0 - +24 semitone) ll : ignored
7FH 7FH	--- ---	RPN reset Return to no specified parameter of RPN and NRPN. Current setting value is not changed. mm, ll : ignored

● Program change

Status	Second
CnH	ppH

n = MIDI channel number : 0H - FH (ch.1 - ch.16)
 pp = Program number : 00H - 7FH (prog.1 - prog.128)

* The voices already on before receiving a program change message aren't affected. The tone will change to the new voice after the program change is received.
 * Ignored when "Rx.Program change = OFF".
 * In the drum part, JV-30 doesn't receive Program change message when the Bank is 129 - 16384 (the value of the control change 00H is not 00H).

● Channel pressure

Status	Second
DnH	vvH

n = MIDI channel number : 0H - FH (ch.1 - ch.16)
 vv = Value : 00H - 7FH (0 - 127)

* Ignored when "Rx.Channel pressure = OFF".
 * Effect to the parameter set on "MOD controller function".
 No initial setting available.

● Pitch bend change

Status	Second	Third
EnH	llH	mmH

n = MIDI channel number : 0H - FH (ch.1 - ch.16)
 mm, ll = Value : 00H, 00H - 40H, 00H - 7FH, 7FH
 (-8192 - 0 - +8191)

* Ignored when "Rx.Pitch bend change = OFF".
 * Effect to the parameter set on "MOD controller function".
 The default setting is pitch bend.

■ Channel Mode Message

● All sounds off

Status	Second	Third
BnH	7nH	00H

n = MIDI channel number : 0H - FH (ch.1 - ch.16)

*When "All sounds off" is received, all sounds on specified channel turn off immediately.
However, the state of channel messages does not change.

● Reset all controllers

Status	Second	Third
BnH	79H	00H

n = MIDI channel number : 0H - FH (ch.1 - ch.16)

*When "reset all controllers" is received, the controller value of a specified channel returns to the default value.

Controller	Value
Pitch bend change	± 0 (Center)
Polyphonic key pressure	0 (off)
Channel pressure	0 (off)
Modulation	0 (off)
Expression	127 (maximum)
Hold1	0 (off)
Portamento	0 (off)
Sostenuto	0 (off)
Soft	0 (off)
RPN	No specified parameter, value is not changed.
NRPN	No specified parameter, value is not changed.

● All notes off

Status	Second	Third
BnH	7BH	00H

n = MIDI channel number : 0H - FH (ch.1 - ch.16)

*When "All notes off" is received, all notes are turned off in the specified channel.
However, sound continues when hold1 and/or sostenuto is on.

● OMNI OFF

Status	Second	Third
BnH	7CH	00H

n = MIDI channel number : 0H - FH (ch.1 - ch.16)

*OMNI OFF is only recognized as "all notes off". Mode doesn't change.

● OMNI ON

Status	Second	Third
BnH	7DH	00H

n = MIDI channel number : 0H - FH (ch.1 - ch.16)

*OMNI ON is only recognized as "all notes off". Mode doesn't change (OMNI OFF remains).

● MONO

Status	Second	Third
BnH	7EH	mmH

n = MIDI channel number : 0H - FH (ch.1 - ch.16)

mm = number of mono : 00H - 10H (0 - 16)

*MONO is recognized as "all sounds off". The specified channel turns to Mode4 (m = 1), even if mm is not equal to 1 (mm is ignored).

● POLY

Status	Second	Third
BnH	7FH	00H

n = MIDI channel number : 0H - FH (ch.1 - ch.16)

*POLY is recognized as "all sounds off". The specified channel turns to Mode3.

■ System Realtime Message

● Active sensing

Status
FEH

*Having received an "active sensing" message, JV-30 expects to receive additional active sensing message within 300 ms. If the interval is over 420 milli-second, JV-30 execute "All sounds off", "All notes off" and "Reset all controllers" and returns to normal operation. (Monitoring of active sensing messages will terminate.)

■ System Exclusive Message

Status	Data
F0H	iiH, ddH, ..., eeH
F7H	

F0H : System exclusive
ii = ID number : 41H (65), 7EH (126)
dd, ..., ee = data : 00H - 7FH (0 - 127)
F7H : EOx (End of Exclusive/System common)

*Ignored when "Rx SysEx : OFF".

*JV-30 can receive mode change, data request (RQ1) and data set (DT1).

*Refer to section 3, 4.

■ System Exclusive Message of Mode Change

● GS Reset

Status	Data Byte	Status
F0H	41H, 10H, 42H, 12H, 40H, 00H, 7FH, 00H, 41H	F7H

Byte	Description
F0H	Exclusive status
41H	Manufacturer's ID (Roland)
10H	Device ID (UNIT # = 17)
42H	Model ID (GS)
12H	Command ID (DT1)
40H	Address MSB
00H	
7FH	Address LSB
00H	Data (GS reset)
41H	Check sum
F7H	EOx (End of exclusive)

*Receiving this message, all the internal parameters are set to the GS default setting, and can receive GS MIDI data correctly. Set Rx.NRPN = ON.
*It takes about 50ms to execute this message. Please take a rest before the next messages.

*Ignored when "Rx GS Reset : OFF".

● Turn General MIDI System On

Status	Data Byte	Status
F0H	7EH, 7FH, 09H, 01H	F7H

Byte	Description
F0H	Exclusive status
7EH	ID Number (Universal non-real time message)
7FH	ID of target device (Broadcast)
09H	sub-ID # 1 (General MIDI message)
01H	sub-ID # 2 (General MIDI On)
F7H	EOx (End of exclusive)

*Receiving this message, all the internal parameters are set to the General MIDI Level 1 default setting even if in the any mode, and can play the General MIDI score (level 1) correctly. Set Rx.NRPN = OFF.
The Bank select messages are ignored when receiving this message.

*It takes about 50ms to execute this message. Please take a rest before the next messages.

*Ignored when "Rx GS Reset : OFF".

2. Transmit data

Channel Voice Message

he message is transmitted through the MIDI Tx Channel. When set to PART transmission takes place on the MIDI channel set for the currently Part.

Note off

Status	Second	Third
8nH	kkH	vvH
n = MIDI channel number	: 0H - FH (ch.1 - ch.16)	
kk = Note number	: 00H - 7FH (0 - 127)	
vv = Velocity	: 01H - 7FH (1 - 127)	

Note on

Status	Second	Third
9nH	kkH	vvH
n = MIDI channel number	: 0H - FH (ch.1 - ch.16)	
kk = Note number	: 00H - 7FH (0 - 127)	
vv = Velocity	: 01H - 7FH (1 - 127)	

Control change

Bank select

Status	Second	Third
BnH	00H	mmH
BnH	20H	llH

n = MIDI channel number : 0H - FH (ch.1 - ch.16)
mm, ll = Value : 00H, 00H - 7FH, 7FH (bank.1 - bank.16384)

*This message is transmitted only when the BANK/NUMBER and/or VARIATION button are pressed. The message contains only the value assigned to each button on the panel.

*The "Variation number" of the JV-30 is written as the decimal number that is the value of MSB (Control change number 00H) of the Bank select.

Modulation

Status	Second	Third
BnH	01H	vvH

n = MIDI channel number : 0H - FH (ch.1 - ch.16)
vv = Modulation depth : 00H - 7FH (0 - 127)

*This message is transmitted when the Modulation Lever is used.

Portamento time

Status	Second	Third
BnH	05H	vvH

n = MIDI channel number : 0H - FH (ch.1 - ch.16)
vv = Portamento time : 00H - 7FH (0 - 127)

*The current setting value is transmitted when the Portamento button is turned on.

Data entry

Status	Second	Third
BnH	06H	vvH

n = MIDI channel number : 0H - FH (ch.1 - ch.16)
vv = Control Value : 00H - 7FH (0 - 127)

Panpot

Status	Second	Third
BnH	0AH	vvH

n = MIDI channel number : 0H - FH (ch.1 - ch.16)
vv = Panpot : 00H - 7FH (Left - Center - Right)

*This message is transmitted when the edit slider is operated with MIDI Control Mode.

Expression

Status	Second	Third
BnH	0BH	vvH

n = MIDI channel number : 0H - FH (ch.1 - ch.16)
vv = Expression : 00H - 7FH (0 - 127)

*This message is transmitted when the edit slider is operated with MIDI Control Mode. The value corresponds to the Level of Part.

Hold1

Status	Second	Third
BnH	40H	vvH

n = MIDI channel number : 0H - FH (ch.1 - ch.16)
vv = Hold : 00H, 7FH (0, 127) 0 = OFF, 127 = ON

*This message is transmitted when the Hold Pedal is depressed.

Portamento

Status	Second	Third
BnH	41H	vvH

n = MIDI channel number : 0H - FH (ch.1 - ch.16)
vv = Portamento : 00H, 7FH (0, 127) 0 = OFF, 127 = ON

*This message is transmitted when the Portamento button is pressed.

NRPN MSB/LSB

Status	Second	Third
BnH	63H	mmH
BnH	62H	llH

n = MIDI channel number : 0H - FH (ch.1 - ch.16)
mm = MSB of the specified parameter by NRPN
ll = LSB of the specified parameter by NRPN

*This message is transmitted when tone change is made on the panel.

** NRPN **

NRPN (Non Registered Parameter Number) is an expanded control change message.

Each function of NRPN is described by individual manufacture.

JV-30 transmits NRPN with Bank select and Program change corresponding to the tone when tone change is made.

NRPN	Data Entry	Description	
MSB	LSB	MSB	
01H	08H	mmH	Vibrato rate relative change on specified channel mm : 0EH - 40H - 72H (-50 - 0 - +50)
01H	09H	mmH	Vibrato depth relative change on specified channel mm : 0EH - 40H - 72H (-50 - 0 - +50)
01H	0AH	mmH	Vibrato delay relative change on specified channel mm : 0EH - 40H - 72H (-50 - 0 - +50)
01H	20H	mmH	TVF cutoff frequency relative change on specified channel mm : 0EH - 40H - 50H (-50 - 0 - +16)
01H	21H	mmH	TVF resonance relative change on specified channel mm : 0EH - 40H - 72H (-50 - 0 - +50)
01H	63H	mmH	TVF & TVA Env. Attack time relative change on specified channel mm : 0EH - 40H - 72H (-50 - 0 - +50)
01H	64H	mmH	TVF & TVA Env. Decay time relative change on specified channel mm : 0EH - 40H - 72H (-50 - 0 - +50)
01H	65H	mmH	TVF & TVA Env. Release time relative change on specified channel mm : 0EH - 40H - 72H (-50 - 0 - +50)

*Data entry LSB is ignored.

Ext Control Number

Status	Second	Third
BnH	ccH	vvH

n = MIDI channel number : 0H - FH (ch.1 - ch.16)
cc = Control number : 00H - 09H, 0CH - 1FH, 40H - 5FH
vv = Control value : 00H - 7FH (0 - 127)

*Control number can be assigned to the right one of the edit sliders when you select MIDI control mode.

Program change

Status	Second
CnH	ppH

n = MIDI channel number : 0H - FH (ch.1 - ch.16)
pp = Program number : 00H - 7FH (prog.1 - prog.128)

*This message is transmitted when tone change is made with PRESET/USER, BANK, NUMBER, VARIATION and/or DRUM1/2 buttons.

● Pitch bend change

Status	Second	Third
EaH	llH	mmH
n = MIDI channel number	: 0H - FH (ch.1 - ch.16)	
mm, ll = Value	: 00H, 00H - 7FH, 7FH (- 8192 - + 8191)	

*This message is transmitted when Pitch Bender is operated. The resolution is 12 bits including direction.

■ Channel Mode Message

● Reset all controllers

Status	Second	Third
BnH	79H	00H
n = MIDI channel number	: 0H - FH (ch.1 - ch.16)	

*This message is transmitted to external equipments when used to change Part or MIDI receive channel.

● All notes off

Status	Second	Third
BnH	7BH	00H
n = MIDI channel number	: 0H - FH (ch.1 - ch.16)	

*This message is transmitted external equipments when used to change Part or MIDI receive channel.

● MONO

Status	Second	Third
BnH	7EH	01H
n = MIDI channel number	: 0H - FH (ch.1 - ch.16)	

*This message is transmitted when the Solo button is turned on.

● POLY

Status	Second	Third
BnH	7FH	00H
n = MIDI channel number	: 0H - FH (ch.1 - ch.16)	

*This message is transmitted when the Solo button is turned off.

■ System real time message

● Active sensing

Status
FEH

*Transmit at about 250 milli-second interval.

■ System Exclusive Message

Status	Data
F0H	iiH, ddH,...eeH
F7H	
F0H	: System exclusive
ii = ID number	: 41H (65)
dd...ee = data	: 00H - 7FH (0 - 127)
F7H	: EOX (End of Exclusive/System common)

*Refer to section 3.4.

3. Exclusive communications

JV-30 can transmit and receive the parameters using system exclusive message.

Model ID of JV-30 is 42H (GS) and 4DH (JV-30).
Device ID is 00H - 1FH.

■ One way communication

● Request data 1 RQ1 (11H)

Byte	Description
F0H	Exclusive status
41H	Manufacturer's ID (Roland)
dev	Device ID (dev : 00H - 1FH)
mdl	Model ID (mdl : 4DH or 42H)
llH	Command ID (RQ1)
aaH	Address MSB
bbH	Address
ccH	Address LSB
ssH	Size MSB
ttH	Size
uuH	Size LSB
sum	Check sum
F7H	EOX (End of exclusive)

● Data set 1 DT1 (12H)

Byte	Description
F0H	Exclusive status
41H	Manufacturer's ID (Roland)
dev	Device ID (dev : 00H - 1FH)
mdl	Model ID (mdl : 4DH or 42H)
llH	Command ID (DT1)
aaH	Address MSB
bbH	Address
ccH	Address LSB
ddH	Data
l	
eeH	Data
sum	Check sum
F7H	EOX (End of exclusive)

4. Parameter Address Map

The address and size are described with 7-bit hexadecimal.

Address	MSB	LSB
Binary	0aaa aaaa	0bbb bbbb 0ccc cccc
Hexadecimal	AA	BB CC
Size	MSB	LSB
Binary	0sss ssss	0ttt tttt 0uuu uuuu
Hexadecimal	SS	TT UU

Parameter base address

There are two types of the JV-30 exclusive message. One is an individual parameter communication, another is a bulk dump communication.

Coarse address map of the exclusive communication is shown below :

< Model ID = 4DH >

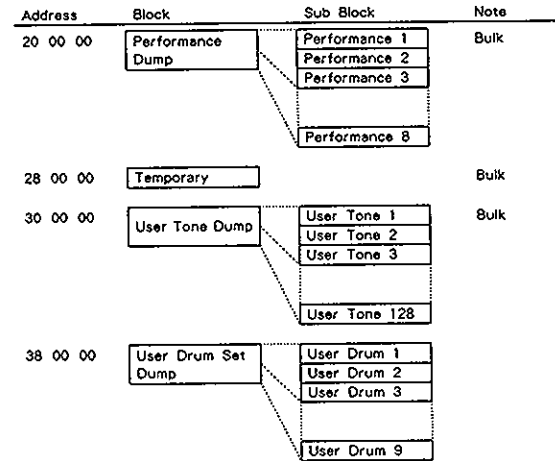

< Model ID = 42H >

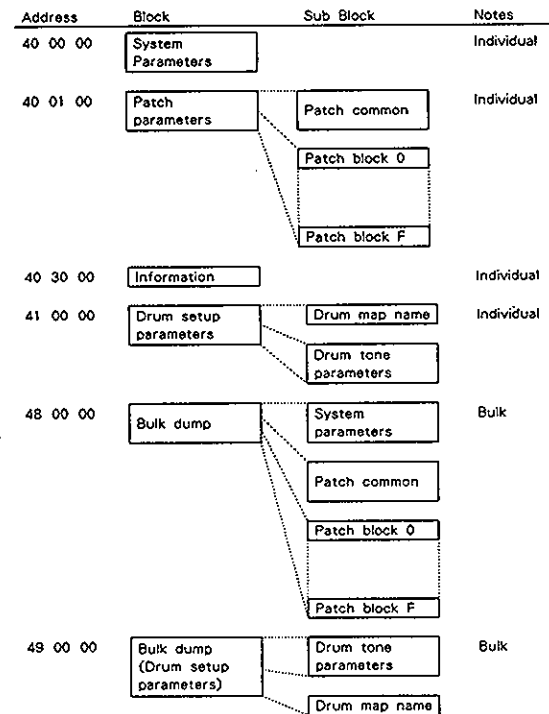

Notes: Using address of individual parameter

One system exclusive message "F0 F7" can only have one parameter. You cannot use any address having "*" for the top address in a system exclusive message.

< Model ID = 4DH >

[PERFORMANCE DUMP]

1-packet = 128byte (MIDI)

--- PERFORMANCE ALL ((18 + 32 + (16 * 14)) * 8 = 0x890byte)
 --- 0x890 * 2 (nibble) = 22 20 (MIDI)

Address (H)	SIZE (H)	Date (H)	Description
20 00 00	00 22 20		
#			35 packets
20 22 1F #			

--- PERFORMANCE (18 + 32 + (16 * 14) = 0x112byte)
 --- 0x112 * 2 (nibble) = 04 24 (MIDI)

Address (H)	SIZE (H)	Date (H)	Description
20 00 00	00 04 24		
#			performance 1 [Table] 5 packets
20 04 23 #			
20 04 24	00 04 24		performance 2 5 packets
#			
20 08 47 #			
20 08 48	00 04 24		performance 3 5 packets
#			
20 0C 6B #			
20 0C 6C	00 04 24		performance 4 5 packets
#			
20 11 0F #			
20 11 10	00 04 24		performance 5 5 packets
#			
20 15 33 #			
20 15 34	00 04 24		performance 6 5 packets
#			
20 19 57 #			
20 19 58	00 04 24		performance 7 5 packets
#			
20 1D 7B #			
20 1D 7C	00 04 24		performance 8 5 packets
#			
20 22 1F #			

[TEMPORARY]

--- TEMPORARY (18 + 32 + (16 * 14) = 0x112byte)
 --- 0x112 * 2 (nibble) = 04 24 (MIDI)

Address (H)	SIZE (H)	Description
28 00 00	00 04 24	
#		5 packets
28 04 23 #		

[USER TONE DUMP]

--- USER TONE (10 * 128 = 0x500byte)
 --- 0x500 * 2 (nibble) = 14 00 (MIDI)

Address (H)	SIZE (H)	Description
30 00 00	00 14 00	
#		20 packets
30 13 7F #		

[USER DRUM SET DUMP]

--- USER DRUM SET ALL (512 * 9 = 0x1200byte)
 --- 0x1200 * 2 (nibble) = 48 00 (MIDI)

Address (H)	SIZE (H)	Description
38 00 00	00 48 00	
#		72 packets
38 47 7F #		

--- USER DRUM SET (S12 = 0x200byte)
 --- 0x200 * 2 (nibbleize) = 80 00 (MIDI)

Address (H)	SIZE (H)	Description
38 00 00	00 08 00	
#		Drum Set 1 8 packets
38 07 7F #		
38 08 00	00 08 00	
#		Drum Set 2 8 packets
38 0F 7F #		
38 10 00	00 08 00	
#		Drum Set 3 8 packets
38 17 7F #		
38 18 00	00 08 00	
#		Drum Set 4 8 packets
38 1F 7F #		
38 20 00	00 08 00	
#		Drum Set 5 8 packets
38 27 7F #		
38 28 00	00 08 00	
#		Drum Set 6 8 packets
38 2F 7F #		
38 30 00	00 08 00	
#		Drum Set 7 8 packets
38 37 7F #		
38 38 00	00 08 00	
#		Drum Set 8 8 packets
38 3F 7F #		
38 40 00	00 08 00	
#		Drum Set 9 8 packets
38 47 7F #		

< Model ID = 42H >

[SYSTEM PARAMETERS]

Address (H)	SIZE (H)	Data (H)	Parameter	Description	Default Value (H)
40 00 00	00 00 04	0018 - 07E8	MASTER TUNE	- 100.0 - + 100.0 [cent]	00 04 00 00
40 00 01 #				Use nibblized data.	
40 00 02 #					
40 00 03 #					
40 00 04	00 00 01	00 - 7F	MASTER VOLUME	0 - 127	7F
40 00 05	00 00 01	28 - 58	MASTER KEY-SHIFT	- 24 - + 24semitones	40
40 00 06	00 00 01	00 - 7F	MASTER PAN		40
40 00 7F	00 00 01	00, 7F	00: ENTER GS MODE		---
			System reset and set all internal parameters to the default setting.		
			7F: EXIT GS MODE		
			Set to the performance 1 setting.		

For example: If you set + 100.0 cents for master tune, you must send the message as follows.
 F0 41 10 42 12 40 00 00 00 07 0E 08 sum F7

If you set 100 (decimal) for master volume, you must send the message as follows.
 F0 41 10 42 12 40 00 04 64 sum F7

[PATCH PARAMETERS]

*n...block number (0 - F). Part 1 (default MIDI ch = 1) n = 1
 : : :
 Part 9 (default MIDI ch = 9) n = 9
 Part10 (default MIDI ch = 10) n = 0
 Part11 (default MIDI ch = 11) n = A
 : : :
 Part16 (default MIDI ch = 16) n = F

*x...MIDI channel number (0 - F).

Address (H)	SIZE (H)	Data (H)	Parameter	Description	Default Value (H)
40 01 10	00 00 10	00 - 17	VOICE RESERVE	Part 10 (Drums)	02
40 01 11 #				Part 1	06
40 01 12 #				Part 2	02
40 01 13 #				Part 3	02
40 01 14 #				Part 4	02
40 01 15 #				Part 5	02
40 01 16 #				Part 6	02
40 01 17 #				Part 7	02
40 01 18 #				Part 8	02
40 01 19 #				Part 9	02
40 01 1A #				Part 11	00
40 01 : #				:	
40 01 1F #				Part 16	00

The sum of voice reserves must be less than or equal to the voice number of the generator. For example, 17H is the maximum value for a 24 voice sound generator.

Address (H)	SIZE (H)	Data (H)	Parameter	Description	Default Value (H)
40 01 30	00 00 01	00 - 07	REVERB MACRO	00 : Room 1 01 : Room 2 02 : Room 3 03 : Hall 1 04 : Hall 2 05 : Plate 06 : Delay 07 : Panning Delay	04
40 01 31	00 00 01	00 - 07	REVERB CHARACTER		04
40 01 32	00 00 01	00 - 07	REVERB PRE-LPF		00
40 01 33	00 00 01	00 - 7F	REVERB LEVEL		40
40 01 34	00 00 01	00 - 7F	REVERB TIME		40
40 01 35	00 00 01	00 - 7F	REVERB DELAY FEEDBACK		00
40 01 36	00 00 01	00 - 7F	REVERB SEND LEVEL TO CHORUS		00
40 01 38	00 00 01	00 - 07	CHORUS MACRO	00 : Chorus 1 01 : Chorus 2 02 : Chorus 3 03 : Chorus 4 04 : Feedback Chorus 05 : Flanger 06 : Short Delay 07 : Short Delay (FB)	02
40 01 39	00 00 01	00 - 07	CHORUS PRE-LPF		00
40 01 3A	00 00 01	00 - 7F	CHORUS LEVEL		40
40 01 3B	00 00 01	00 - 7F	CHORUS FEEDBACK		08
40 01 3C	00 00 01	00 - 7F	CHORUS DELAY		50
40 01 3D	00 00 01	00 - 7F	CHORUS RATE		03
40 01 3E	00 00 01	00 - 7F	CHORUS DEPTH		13
40 01 3F	00 00 01	00 - 7F	CHORUS SEND LEVEL TO REVERB		00
40 1n 00	00 00 02	00 - 7F	TONE NUMBER	CC # 00 VALUE	00
40 1n 01 #	00 00 01	00 - 7F		P.C. VALUE	00
40 1n 02	00 00 01	00 - 10	Rx. CHANNEL	1 - 16, OFF	same as the Part #
40 1n 03	00 00 01	00 - 01	Rx. PITCH BEND	OFF/ON	01
40 1n 04	00 00 01	00 - 01	Rx. CH PRESSURE (CAf)	OFF/ON	01
40 1n 05	00 00 01	00 - 01	Rx. PROGRAM CHANGE	OFF/ON	01
40 1n 06	00 00 01	00 - 01	Rx. CONTROL CHANGE	OFF/ON	01
40 1n 07	00 00 01	00 - 01	Rx. POLY PRESSURE (PAf)	OFF/ON	01
40 1n 08	00 00 01	00 - 01	Rx. NOTE MESSAGE	OFF/ON	01
40 1n 09	00 00 01	00 - 01	Rx. RPN	OFF/ON	01
40 1n 0A	00 00 01	00 - 01	Rx. NRPN	OFF/ON	00
Rx. NRPN is set to OFF by power on reset, but it is set to ON by "GS RESET".					
40 1n 0B	00 00 01	00 - 01	Rx. MODULATION	OFF/ON	01
40 1n 0C	00 00 01	00 - 01	Rx. VOLUME	OFF/ON	01
40 1n 0D	00 00 01	00 - 01	Rx. PANPOT	OFF/ON	01
40 1n 0E	00 00 01	00 - 01	Rx. EXPRESSION	OFF/ON	01
40 1n 0F	00 00 01	00 - 01	Rx. HOLD!	OFF/ON	01
40 1n 10	00 00 01	00 - 01	Rx. PORTAMENTO	OFF/ON	01
40 1n 11	00 00 01	00 - 01	Rx. SOSTENUTO	OFF/ON	01
40 1n 12	00 00 01	00 - 01	Rx. SOFT	OFF/ON	01
The ON/OFF setting of the receiving switch (40 1n 03 - 40 1n 12) must be executed while the unit is not sounding.					
40 1n 13	00 00 01	00 - 01	MONO/POLY MODE	Mono/Poly	01
40 1n 14	00 00 01	00 - 02	(= Bx 7E 01/Bx 7F 00) ASSIGN MODE	0 = SINGLE 1 = LIMITED - MULTI 2 = FULL - MULTI	00 at n = 0 01 at n ≠ 0
40 1n 15	00 00 01	00 - 02	USE FOR RHYTHM PART	0 = OFF 1 = MAP1 2 = MAP2	00 at n ≠ 0 01 at n = 0
40 1n 16	00 00 01	28 - 58	PITCH KEY SHIFT [semitone]	- 24 - + 24	40
40 1n 17	00 00 02	08 - F8	PITCH OFFSET FINE	- 12.0 - + 12.0 [Hz]	08 00
40 1n 18 #			Use nibbled data.		
40 1n 19	00 00 01	00 - 7F	PART LEVEL (= Bx 07 vv)	0 - 127	64
40 1n 1A	00 00 01	00 - 7F	VELOCITY SENSE DEPTH	0 - 127	40
40 1n 1B	00 00 01	00 - 7F	VELOCITY SENSE OFFSET	0 - 127	40
40 1n 1C	00 00 01	00 - 7F	PART PANPOT (= Bx 0A vv, except random)	Random. - 63 (LEFT) - + 63 (RIGHT)	40
40 1n 1D	00 00 01	00 - 7F	KEY RANGE LOW	C - 1 - G9	00
40 1n 1E	00 00 01	00 - 7F	KEY RANGE HIGH	C - 1 - G9	7F
40 1n 1F	00 00 01	00 - 5F	CC1 CONTROLLER NUMBER	0 - 95	10
40 1n 20	00 00 01	00 - 5F	CC2 CONTROLLER NUMBER	0 - 95	11
40 1n 21	00 00 01	00 - 7F	CHORUS SEND LEVEL (= Bx 5D vv)	0 - 127	00
40 1n 22	00 00 01	00 - 7F	REVERB SEND LEVEL (= Bx 5B vv)	0 - 127	28
40 1n 30	00 00 01	0E - 72	TONE MODIFY 1 Vibrato rate (= Bx 63 01 62 08 06 vv)	- 50 - + 50	40
40 1n 31	00 00 01	0E - 72	TONE MODIFY 2 Vibrato depth (= Bx 63 01 62 09 06 vv)	- 50 - + 50	40
40 1n 32	00 00 01	0E - 50	TONE MODIFY 3 TVF cutoff freq.(= Bx 63 01 62 20 06 vv)	- 50 - + 16	40

Address (H)	SIZE (H)	Data (H)	Parameter	Description	Default Value (H)
40 1n 33	00 00 01	0E - 72	TONE MODIFY 4 TVF resonance (= Bx 63 01 62 21 06 vv)	- 50 - + 50	40
40 1n 34	00 00 01	0E - 72	TONE MODIFY 5 TVF & TVA Env. attack (= Bx 63 01 62 63 06 vv)	- 50 - + 50	40
40 1n 35	00 00 01	0E - 72	TONE MODIFY 6 TVF & TVA Env. decay (= Bx 63 01 62 64 06 vv)	- 50 - + 50	40
40 1n 36	00 00 01	0E - 72	TONE MODIFY 7 TVF & TVA Env.release (= Bx 63 01 62 66 06 vv)	- 50 - + 50	40
40 1n 37	00 00 01	0E - 72	TONE MODIFY 8 Vibrato delay (= Bx 63 01 62 0A 06 vv)	- 50 - + 50	40
40 1n 40	00 00 0C	00 - 7F	SCALE TUNING C	- 64 - + 63 [cent]	40
40 1n 41 #		00 - 7F	SCALE TUNING C #	- 64 - + 63 [cent]	40
40 1n 42 #		00 - 7F	SCALE TUNING D	- 64 - + 63 [cent]	40
40 1n 43 #		00 - 7F	SCALE TUNING D #	- 64 - + 63 [cent]	40
40 1n 44 #		00 - 7F	SCALE TUNING E	- 64 - + 63 [cent]	40
40 1n 45 #		00 - 7F	SCALE TUNING F	- 64 - + 63 [cent]	40
40 1n 46 #		00 - 7F	SCALE TUNING F #	- 64 - + 63 [cent]	40
40 1n 47 #		00 - 7F	SCALE TUNING G	- 64 - + 63 [cent]	40
40 1n 48 #		00 - 7F	SCALE TUNING G #	- 64 - + 63 [cent]	40
40 1n 49 #		00 - 7F	SCALE TUNING A	- 64 - + 63 [cent]	40
40 1n 4A #		00 - 7F	SCALE TUNING A #	- 64 - + 63 [cent]	40
40 1n 4B #		00 - 7F	SCALE TUNING B	- 64 - + 63 [cent]	40
40 2n 00	00 00 01	28 - 58	MOD PITCH CONTROL	- 24 - + 24 [semitone]	40
40 2n 01	00 00 01	00 - 7F	MOD TVF CUTOFF CONTROL	- 9600 - + 9600 [cent]	40
40 2n 02	00 00 01	00 - 7F	MOD AMPLITUDE CONTROL	- 100.0 - + 100.0 [%]	40
40 2n 03	00 00 01	00 - 7F	MOD LFO1 RATE CONTROL	- 10.0 - + 10.0 [Hz]	40
40 2n 04	00 00 01	00 - 7F	MOD LFO1 PITCH DEPTH	0 - 600 [cent]	0A
40 2n 05	00 00 01	00 - 7F	MOD LFO1 TVF DEPTH	0 - 2400 [cent]	00
40 2n 06	00 00 01	00 - 7F	MOD LFO1 TVA DEPTH	0 - 100.0 [%]	00
40 2n 07	00 00 01	00 - 7F	MOD LFO2 RATE CONTROL	- 10.0 - + 10.0 [Hz]	40
40 2n 08	00 00 01	00 - 7F	MOD LFO2 PITCH DEPTH	0 - 600 [cent]	00
40 2n 09	00 00 01	00 - 7F	MOD LFO2 TVF DEPTH	0 - 2400 [cent]	00
40 2n 0A	00 00 01	00 - 7F	MOD LFO2 TVA DEPTH	0 - 100.0 [%]	00
40 2n 10	00 00 01	40 - 58	BEND PITCH CONTROL	0 - 24 [semitone]	42
40 2n 11	00 00 01	00 - 7F	BEND TVF CUTOFF CONTROL	- 9600 - + 9600 [cent]	40
40 2n 12	00 00 01	00 - 7F	BEND AMPLITUDE CONTROL	- 100.0 - + 100.0 [%]	40
40 2n 13	00 00 01	00 - 7F	BEND LFO1 RATE CONTROL	- 10.0 - + 10.0 [Hz]	40
40 2n 14	00 00 01	00 - 7F	BEND LFO1 PITCH DEPTH	0 - 600 [cent]	00
40 2n 15	00 00 01	00 - 7F	BEND LFO1 TVF DEPTH	0 - 2400 [cent]	00
40 2n 16	00 00 01	00 - 7F	BEND LFO1 TVA DEPTH	0 - 100.0 [%]	00
40 2n 17	00 00 01	00 - 7F	BEND LFO2 RATE CONTROL	- 10.0 - + 10.0 [Hz]	40
40 2n 18	00 00 01	00 - 7F	BEND LFO2 PITCH DEPTH	0 - 600 [cent]	00
40 2n 19	00 00 01	00 - 7F	BEND LFO2 TVF DEPTH	0 - 2400 [cent]	00
40 2n 1A	00 00 01	00 - 7F	BEND LFO2 TVA DEPTH	0 - 100.0 [%]	00
40 2n 20	00 00 01	28 - 58	CAf PITCH CONTROL	- 24 - + 24 [semitone]	40
40 2n 21	00 00 01	00 - 7F	CAf TVF CUTOFF CONTROL	- 9600 - + 9600 [cent]	40
40 2n 22	00 00 01	00 - 7F	CAf AMPLITUDE CONTROL	- 100.0 - + 100.0 [%]	40
40 2n 23	00 00 01	00 - 7F	CAf LFO1 RATE CONTROL	- 10.0 - + 10.0 [Hz]	40
40 2n 24	00 00 01	00 - 7F	CAf LFO1 PITCH DEPTH	0 - 600 [cent]	00
40 2n 25	00 00 01	00 - 7F	CAf LFO1 TVF DEPTH	0 - 2400 [cent]	00
40 2n 26	00 00 01	00 - 7F	CAf LFO1 TVA DEPTH	0 - 100.0 [%]	00
40 2n 27	00 00 01	00 - 7F	CAf LFO2 RATE CONTROL	- 10.0 - + 10.0 [Hz]	40
40 2n 28	00 00 01	00 - 7F	CAf LFO2 PITCH DEPTH	0 - 600 [cent]	00
40 2n 29	00 00 01	00 - 7F	CAf LFO2 TVF DEPTH	0 - 2400 [cent]	00
40 2n 2A	00 00 01	00 - 7F	CAf LFO2 TVA DEPTH	0 - 100.0 [%]	00
40 2n 30	00 00 01	28 - 58	PAf PITCH CONTROL	- 24 - + 24 [semitone]	40
40 2n 31	00 00 01	00 - 7F	PAf TVF CUTOFF CONTROL	- 9600 - + 9600 [cent]	40
40 2n 32	00 00 01	00 - 7F	PAf AMPLITUDE CONTROL	- 100.0 - + 100.0 [%]	40
40 2n 33	00 00 01	00 - 7F	PAf LFO1 RATE CONTROL	- 10.0 - + 10.0 [Hz]	40
40 2n 34	00 00 01	00 - 7F	PAf LFO1 PITCH DEPTH	0 - 600 [cent]	00
40 2n 35	00 00 01	00 - 7F	PAf LFO1 TVF DEPTH	0 - 2400 [cent]	00
40 2n 36	00 00 01	00 - 7F	PAf LFO1 TVA DEPTH	0 - 100.0 [%]	00
40 2n 37	00 00 01	00 - 7F	PAf LFO2 RATE CONTROL	- 10.0 - + 10.0 [Hz]	40
40 2n 38	00 00 01	00 - 7F	PAf LFO2 PITCH DEPTH	0 - 600 [cent]	00
40 2n 39	00 00 01	00 - 7F	PAf LFO2 TVF DEPTH	0 - 2400 [cent]	00
40 2n 3A	00 00 01	00 - 7F	PAf LFO2 TVA DEPTH	0 - 100.0 [%]	00
40 2n 40	00 00 01	28 - 58	CC1 PITCH CONTROL	- 24 - + 24 [semitone]	40
40 2n 41	00 00 01	00 - 7F	CC1 TVF CUTOFF CONTROL	- 9600 - + 9600 [cent]	40
40 2n 42	00 00 01	00 - 7F	CC1 AMPLITUDE CONTROL	- 100.0 - + 100.0 [%]	40
40 2n 43	00 00 01	00 - 7F	CC1 LFO1 RATE CONTROL	- 10.0 - + 10.0 [Hz]	40
40 2n 44	00 00 01	00 - 7F	CC1 LFO1 PITCH DEPTH	0 - 600 [cent]	00
40 2n 45	00 00 01	00 - 7F	CC1 LFO1 TVF DEPTH	0 - 2400 [cent]	00
40 2n 46	00 00 01	00 - 7F	CC1 LFO1 TVA DEPTH	0 - 100.0 [%]	00
40 2n 47	00 00 01	00 - 7F	CC1 LFO2 RATE CONTROL	- 10.0 - + 10.0 [Hz]	40
40 2n 48	00 00 01	00 - 7F	CC1 LFO2 PITCH DEPTH	0 - 600 [cent]	00
40 2n 49	00 00 01	00 - 7F	CC1 LFO2 TVF DEPTH	0 - 2400 [cent]	00
40 2n 4A	00 00 01	00 - 7F	CC1 LFO2 TVA DEPTH	0 - 100.0 [%]	00

Address (H)	SIZE (H)	Data (H)	Parameter	Description	Default Value (H)
40 2n 50	00 00 01	28 - 58	CC2 PITCH CONTROL	- 24 - + 24 [semitone]	40
40 2n 51	00 00 01	00 - 7F	CC2 TVF CUTOFF CONTROL	- 9600 - + 9600 [cent]	40
40 2n 52	00 00 01	00 - 7F	CC2 AMPLITUDE CONTROL	- 100.0 - + 100.0 [%]	40
40 2n 53	00 00 01	00 - 7F	CC2 LFO1 RATE CONTROL	- 10.0 - + 10.0 [Hz]	40
40 2n 54	00 00 01	00 - 7F	CC2 LFO1 PITCH DEPTH	0 - 600 [cent]	00
40 2n 55	00 00 01	00 - 7F	CC2 LFO1 TVF DEPTH	0 - 2400 [cent]	00
40 2n 56	00 00 01	00 - 7F	CC2 LFO1 TVA DEPTH	0 - 100.0 [%]	00
40 2n 57	00 00 01	00 - 7F	CC2 LFO2 RATE CONTROL	- 10.0 - + 10.0 [Hz]	40
40 2n 58	00 00 01	00 - 7F	CC2 LFO2 PITCH DEPTH	0 - 600 [cent]	00
40 2n 59	00 00 01	00 - 7F	CC2 LFO2 TVF DEPTH	0 - 2400 [cent]	00
40 2n 5A	00 00 01	00 - 7F	CC2 LFO2 TVA DEPTH	0 - 100.0 [%]	00

The LFO is used for creating the internal sounds. In some cases, changing the parameters of LFO1 and LFO2 will not greatly affect the sound.

[DRUM SETUP PARAMETERS]

* m : Map number (0 = MAP1, 1 = MAP2)
 * rr : drums part note number (00 - 7F)

Address (H)	SIZE (H)	Data (H)	Parameter	Description
41 m0 00	00 00 0C	20 - 7F	DRUMS MAP NAME	ASCII Character
41 m0 0B #				
41 m1 rr	00 00 01	00 - 7F	PLAY NOTE NUMBER	Pitch coarse
41 m2 rr	00 00 01	00 - 7F	LEVEL	TVA level
			(= Bx 63 1A 62 rr 06 vv)	
41 m3 rr	00 00 01	00 - 7F	ASSIGN GROUP NUMBER	Non, 1 - 127
41 m4 rr	00 00 01	00 - 7F	PANPOT	Random, - 63 (LEFT) - + 63 (RIGHT)
			(= Bx 63 1C 62 rr 06 vv)	
41 m5 rr	00 00 01	00 - 7F	REVERB LEVEL	0.0 - 1.0
			Multiplicand of the part reverb level	
			(= Bx 63 1D 62 rr 06 vv)	
41 m6 rr	00 00 01	00 - 7F	CHORUS LEVEL	0.0 - 1.0
			Multiplicand of the part chorus level	
			(= Bx 63 1E 62 rr 06 vv)	
41 m7 rr	00 00 01	00 - 01	Rx. NOTE OFF	OFF/ON
41 m8 rr	00 00 01	00 - 01	Rx. NOTE ON	OFF/ON

When you change drum sets, all values of the DRUM SETUP PARAMETERS will be initialized.

[BULK DUMP]

1 - packet = 128byte (MIDI)

--- ALL (8 + 64 + (112 * 16) = 0x748byte)
 --- 0x748 * 2 (nibble) = 1D 10 (MIDI)

Address (H)	SIZE (H)	Data (H)	Parameter	Description
48 00 00	00 1D 10			
48 10 0F #				30 packets

--- SYSTEM PARAMETER (8 = 0x08byte)
 --- 0x08 * 2 (nibble) = 00 10 (MIDI)

Address (H)	SIZE (H)	Data (H)	Parameter	Description
48 00 00	00 00 10			
48 00 0F #				1 packet

--- PATCH COMMON (64 = 0x40byte)
 --- 0x40 * 2 (nibble) = 01 00 (MIDI)

Address (H)	SIZE (H)	Data (H)	Parameter	Description
48 00 10	00 01 00			
48 01 0F #				1 packet

--- PATCH PART (112 = 0x70byte)
 --- 0x70 * 2 (nibbleize) = 01 60 (MIDI)

Address (H)	SIZE (H)	Data (H)	Parameter	Description
48 01 10 #	00 01 60		PART 10 (Block 0)	2 packets
48 02 6F #				
48 02 70 #	00 01 60		PART 1 (Block 1)	2 packets
48 04 4F #				
48 04 50 #	00 01 60		PART 2 (Block 2)	2 packets
48 06 2F #				
48 06 30 #	00 01 60		PART 3 (Block 3)	2 packets
48 08 0F #				
48 08 10 #	00 01 60		PART 4 (Block 4)	2 packets
48 09 6F #				
48 09 70 #	00 01 60		PART 5 (Block 5)	2 packets
48 0B 4F #				
48 0B 50 #	00 01 60		PART 6 (Block 6)	2 packets
48 0D 2F #				
48 0D 30 #	00 01 60		PART 7 (Block 7)	2 packets
48 0F 0F #				
48 0F 10 #	00 01 60		PART 8 (Block 8)	2 packets
48 10 6F #				
48 10 70 #	00 01 60		PART 9 (Block 9)	2 packets
48 12 4F #				
48 12 50 #	00 01 60		PART 11 (Block A)	2 packets
48 14 2F #				
48 14 30 #	00 01 60		PART 12 (Block B)	2 packets
48 16 0F #				
48 16 10 #	00 01 60		PART 13 (Block C)	2 packets
48 17 6F #				
48 17 70 #	00 01 60		PART 14 (Block D)	2 packets
48 19 4F #				
48 19 50 #	00 01 60		PART 15 (Block E)	2 packets
48 1B 2F #				
48 1B 30 #	00 01 60		PART 16 (Block F)	2 packets
48 1D 0F #				

----- DRUM MAP PARAMETER (128 = 80h)
 0x80 * 2 (nibbleize) = 00 02 00 (MIDI)

Address (H)	SIZE (H)	Parameter	Description
49 m0 00 	00 02 00	PLAY NOTE NUMBER	2 packets
49 m1 7F			
49 m2 00 	00 02 00	LEVEL	2 packets
49 m3 7F			
49 m4 00 	00 02 00	ASSIGN GROUP NUMBER	2 packets
49 m5 7F			
49 m6 00 	00 02 00	PANPOT	2 packets
49 m7 7F			
49 m8 00 	00 02 00	REVERB LEVEL	2 packets
49 m9 7F			
49 mA 00 	00 02 00	CHORUS LEVEL	2 packets
49 mB 7F			
49 mC 00 	00 02 00	Rx. NOTE ON/OFF	2 packets
49 mD 7F			
49 mE 00 	00 00 18	DRUM MAP NAME	1 packet
49 mE 17			

m: map number (0 - 1)

MIDI Implementation Chart

Function ...		Transmitted	Recognized	Remarks
Basic Channel	Default Changed	1 - 16 1 - 16	1 - 16 1 - 16 each	Memorized
Mode	Default Messages Altered	Mode 3 MONO, POLY *****	Mode 3 Mode 3, 4 (M = 1)	* 2, Operating
Note Number	True Voice	0 - 127 *****	0 - 127 0 - 127	
Velocity	Note ON Note OFF	○ ×	○ ×	
After Touch	Key's Ch's	×	* 1 * 1	
Pitch Bender		○	* 1	
Control Change	0 - 9, 12 - 31, 64 - 95	* 1 (assignable)	* 3 (MSB only) * 1 * 3 * 3 * 1 * 1 * 1 * 1 * 1 * 1 * 1 * 3 (Reverb) * 3 (Chorus) * 1 * 1 ○ ○	Bank select Modulation Portamento time Data entry Volume Panpot Expression Hold1 Portamento Sostenuto Soft Effect1 depth Effect3 depth NRPN LSB, MSB RPN LSB, MSB All sounds off Reset all controllers
	0, 32	○		
	1	○		
	5	○		
	6, 38	○ (MSB only)		
	7	* 1		
	10	○		
	11	○		
	64	○		
	65	○		
	66	* 1		
	67	* 1		
	91	* 1		
	93	* 1		
98, 99	○ * 4			
100, 101	* 1			
120	* 1			
121	○			
Prog Change	True #	○ *****	* 1 0 - 127	Prog. Number 1 - 128
System Exclusive		○	* 1	
System Common	Song Pos Song Sel Tune	×	×	
System Real Time	Clock Commands	×	×	
Aux Messages	Local ON/OFF All Notes OFF Active Sense Reset	×	* 1 ○ (123 - 125) ○ ×	
Notes	* 1 ○× is selectable * 2 Recognize as m = 1 even if m ≠ 1 * 3 ○× is selectable only when using the receive switch control change (all) * 4 The edit data is transmitted, only tone change.			

Mode 1 : OMNI ON, POLY
Mode 3 : OMNI OFF, POLY

Mode 2 : OMNI ON, MONO
Mode 4 : OMNI OFF, MONO

○ : Yes
× : No

■ How to read a MIDI Implementation Chart

○ : MIDI data that can be transmitted or received.

× : MIDI data that cannot be transmitted or received.

● Basic Channel

The MIDI channel for transmitting (or receiving) MIDI data can be specified over this range. The MIDI channel setting is remembered even when the power is turned off.

● Mode

Most recent keyboard use mode 3 (omni off, poly).

Reception : MIDI data is received only on the specified channels, and played polyphonically.

Transmission : All MIDI data is transmitted on the specified MIDI channel.

* "Mode" refers to MIDI Mode messages.

● Note Number

This is the range of note numbers that can be transmitted (or received). Note number 60 is middle C (C4).

● Velocity

This is the range over which velocity can be transmitted (or received) by Note On and Note Off messages.

● Aftertouch

Key's : Polyphonic Aftertouch

Ch's : Channel Aftertouch

● Pitch Bender

The bender range setting of each Tone determines the range of pitch change caused by Pitch Bender messages. When set to 0, Pitch Bender messages will be ignored.

● Control Change

This indicates the control numbers that can be transmitted (or received), and what they will control. For details, refer to the MIDI implementation.

● Program Change

The program numbers in the chart indicate the actual data. (This is one less than the Tone program numbers.)

● Exclusive

Exclusive message reception can be turned On/Off.

● Common, Real time

These MIDI messages are used to synchronize sequencers and rhythm machines. The JV-30 does not use these messages.

● Aux messages

Mainly, these message are of the type used to prevent problems, such as Active Sensing (Checks whether MIDI cable is in proper condition or not) ; and All Notes Off (Message which terminates the sounding of all notes).

TOPICAL INDEX

● When You Want to Know a Name

- * When you want to know the name and function of a button or slider... Panel Descriptions (p. 6)
- * When you want to know the name and purpose of a jack (plug - in point) on the rear panel...
..... Making the Connections (p. 8)

● Playing Tones

- * When you want to switch between tones... Auditioning the Sounds (p. 12)
- * When you want to play a Variation... Auditioning the Sounds (p. 12)
- * When you want to select or switch between drum sets... Playing Drum Sets (p. 14)
- * When you want to switch Parts... Changing Parts (p. 15)

● Adding Effects Sounds

- * When you want to expand and add depth to the sound... Fat/Octave (p. 16)
- * When you want to turn Chorus on or off... Effects (p. 18)
- * When you want to turn Reverb on or off... Effects (p. 18)
- * When you want to change or shift keys... Transpose (p. 18), Key Shift (p. 23)
- * When you want to play in a higher or lower key without changing positions on the keyboard...
..... Transpose (p. 18), Key Shift (p. 23)
- * When you want to play just one note at a time... Solo (p. 19)
- * When you want to glide smoothly up or down to the next note... Portamento (p. 19)
- * When you want to know how to use the Bender/Modulation lever... Bender/Modulation Lever (p. 19)

● Making Settings

- * When you want to adjust the overall volume... Level (p. 20)
- * When you want to adjust the volume of each Part individually... Level (p. 20)
- * When you want to match the overall tuning of the JV - 30 with an external device... Tune (p. 20)
- * When you want to adjust the left/right output balance of each Part individually... Pan (p. 22)
- * When you want to change from one kind of chorus to another... Chorus Type (p. 21)
- * When you want to adjust the amount of overall chorus effect... Chorus Level (p. 21)
- * When you want to adjust the amount of chorus effect on individual Parts... Chorus Send Depth (p. 22)
- * When you want to change from one kind of reverb to another... Reverb Type (p. 21)
- * When you want to adjust the amount of overall reverb effect... Reverb Level (p. 21)
- * When you want to adjust the amount of reverb effect on individual Parts... Reverb Send Depth (p. 23)
- * When you want to control the amount of added effect with the Bender...
..... Bend Range (p. 23), Modulation Depth (p. 23)
- * When you want the volume of the sound to match how hard you play the keys...
..... Velocity Sense Depth (p. 23), Velocity Sense Offset (p. 23)
- * When you want to prevent stealing of important notes when playing many notes at once... Voice Reserve (p. 23)

● Using Two Tones together

- * When you want to layer two tones... Dual (p. 16)
- * When you want to divide the keyboard and play... Split (p. 16)
- * When you want to change where the dividing point is... Setting the Split Point (p. 17)

● Adding to an Original Sound

- * When you want to add a quaver to the sound... Vibrato (p. 24)
- * When you want to make the sound harder or softer... Filter (p. 25)
- * When you want to make the sound brighter or mellow... Filter (p. 25)
- * When you want a fast response, or a slow build – up after striking a key... Attack Time (p. 25)
- * When you want the sustain the note for as long as you hold down the key... Decay Time (p. 25)
- * When you want the note to die out as soon as you hit the key... Decay Time (p. 25)
- * Whether the note should linger or stop immediately after letting up on the key... Release Time (p. 25)

● Adding to an Original Drum Sound

- * When you want to make the sound higher or lower... Pitch (p. 27)
- * When you want to adjust the volume... Level (p. 27)
- * When you want to change the left/right balance... Pan (p. 27)
- * When you want to add some spaciousness to the sound... Reverb (p. 27)

● Storing

- * When you want to store an edited sound (Tone or Drum Set)...
 Storing Edited Tones (p. 25), Registering Edited Drum Set (p.27)
- * When you want to store all the settings on the JV - 30... Let's Try an Actual Performance (p. 28)

● About MIDI

- * When you want to hook up the MIDI cables... Using MIDI 1 (p. 30)
- * When you want to know something about how MIDI messages are handled... Using MIDI 2 (p. 32)
- * When you want to know which MIDI messages are actually transmitted by the JV - 30...
 Transmitted MIDI Messages (p. 47)
- * When you want to change the Volume/Pan in the Song data... MIDI Controller Features (p. 38)
- * When you want to specify certain Control Change Numbers and change their values...
 MIDI Controller Features (p. 38)

● Others

- * When you want to know the Factory Default Settings... Restoring the Original Settings (p. 39)
- * When you want to make GS settings... Restoring the Original Settings (p. 39)
- * When you want to know the Priority of a Part... Concerning Part Priority Ordering (p. 37)
- * When you want to know the maximum number of simultaneous notes allowed...
 Concerning the Maximum Polyphony (p. 37)
- * I don't understand the notation used in this manual... Conventions Used In This Manual (p. 4)

INDEX

[A]

AC Adaptor	9
AC Adaptor Jack	9
Aftertouch Messages	33
Aftertouch Receive Switch	35
Attack Time	25

[B]

Bank	12
Bender/Modulation Lever	19
Bend Range	23
Bulk Dump (MASTER)	40
Bulk Dump (PART)	40

[C]

Capital Tones	12,48
Channel Aftertouch	33
Channel Messages	32
Chorus Level (MASTER)	21
Chorus On/Off	18
Chorus Send Depth (PART)	22
Chorus Type	21
CM - 64/32L	39
Computer - based Sequencer	30
Control	23
Control Change 0	48
Control Change Messages	33
Control Numbers	38
Cutoff Frequency	25

[D]

Decay Time	25
Delay	21
Demo Songs	10
Device ID Number	35
Drum Sets	14
Drum Tone Dump	40
Dual	16

[E]

Effects	18
Envelope	25
Error Messages	46
Exclusive Messages	33
Exclusive Receive Switch	35

Expression	38
------------------	----

[F]

Fat	16
Filter	25

[G]

General MIDI System	44
GS	44
GS format	39,44
GS Reset Receive Switch	34
GS symbol	44

[H]

Hook	9
------------	---

[K]

Key Mode	16
Key Shift	23

[L]

Level (Drum Sets)	27
Level (MASTER)	20
Level (PART)	22
Local Control	35

[M]

MASTER	20
Master (MIDI)	30
Maximum Polyphony	23,37
Memory Card	41
MIDI	30
MIDI Cables	8
MIDI Channels	32
MIDI Connectors	9
MIDI Controllor Features	38
MIDI Control Mode	47
MIDI Implementation	61
MIDI Implementation Chart	33, 72
MIDI Messages	32
MIDI Patch Bay	31
Modulation Depth	23
MT - 32 Sound Ordering	39
Multi Timbral	36

[N]

Note Messages..... 32
 Note Number 32
 Note Off 32
 Note On 32
 NRPN 47
 NUMBER buttons 12

[O]

Octave..... 16
 One - way Method 30
 OUTPUT Jacks.....9

[P]

Pan (Drum Sets)..... 27
 Pan (MIDI Controllor)..... 38
 Pan (PART) 22
 Parts 15
 PEDAL HOLD Jack.....9
 Pedal Switch8
 Performance Dump Switch 35
 Performances 28
 PHONES Jack9
 Pitch (Drum Sets)..... 27
 Pitch Bend Messages..... 32
 Polyphonic Aftertouch 33
 Portamento 19
 Portamento Time..... 19
 Power Switch9
 Preset Tones 12
 Program Change 48
 Program Change Messages..... 33
 Program Number..... 49

[R]

Receive Channel 35
 Release Time 25
 Resonance 25
 Reverb Depth (Drum Sets)..... 27
 Reverb Level (MASTER) 21
 Reverb On/Off..... 18
 Reverb Send Depth (PART)..... 23
 Reverb Type 21
 ROM Play 10

[S]

Sequencer..... 30
 Series connection 31
 Slave (MIDI)..... 30
 Soft Thru function 36
 Solo..... 19
 Sound Module 30
 Split..... 17
 Split Point 17
 Star connection 31
 Sub - Capitals 48
 System Messages..... 33

[T]

Tone Change Receive Switch 34
 Tone Dump 40
 Tone Number 48
 Transmit Channel 34
 Transpose..... 18
 -- Amount of Transposition 18
 Tune 20

[U]

User Tones 12

[V]

Variation 13,48
 Variation Number..... 48
 Velocity Sens Depth..... 23
 Velocity Sens Offset 23
 Vibrato 24
 Vibrato Delay..... 24
 Vibrato Depth..... 24
 Vibrato Rate 24
 Voice Reserve 23
 Volume9

[W]

Write Procedure 25,27

SPECIFICATIONS

JV-30: 16 Part Multi Timbral Synthesizer

GS response

- **Keyboard**

61 Keys (with velocity)

- **Number of parts**

16 (Two parts can be set in the drum part)

- **Maximum Polyphony**

24 (Voices)

- **Effects**

Reverb

Chorus

- **Internal Memory**

Tones preset : 189

user : 128

Drum sets preset : 9

user : 9

MT-32 sets Tones : 128

Drum set : 1

Performance : 8

- **Display**

16 characters, 2 line

- **Connectors**

Output jacks (L, R)

Phones jack

Pedal Hold Jack

MIDI connectors (IN, OUT, THRU)

- **Dimensions**

978(W) × 279(D) × 84(H) mm

38-1/2" × 11 × 3-4/8"

- **Weight**

6.6 kg/14 lbs 8 oz.

- **Current Draw**

800 mA (9V DC)

- **Accessories**

AC Adaptor

ACI-120 (120V)

ACI-220 (220V)

ACB-240A, ACB-240E (240V)

Owner's Manual

Connection Cable (PJ-1M)

- **Options**

Pedal Switch DP-2/6, FU-5U (BOSS)

Keyboard Stand KS-8

Carrying Bag CB-10

Stereo Headphones RH-20/80/120

MIDI/SYNC Cable MSC-07/15/25/50/100

Monitor Amp MA-12 (BOSS)

For the U.K.

IMPORTANT: THE WIRES IN THIS MAINS LEAD ARE COLOURED IN ACCORDANCE WITH THE FOLLOWING CODE.

BLUE : NEUTRAL
BROWN : LIVE

As the colours of the wires in the mains lead of this apparatus may not correspond with the coloured markings identifying the terminals in your plug proceed as follows:

The wire which is coloured BLUE must be connected to the terminal which is marked with the letter N or coloured BLACK.

The wire which is coloured BROWN must be connected to the terminal which is marked with the letter L or coloured RED.

For Nordic Countries

Apparatus containing Lithium batteries

ADVARSEL!

Lithiumbatteri – Eksplosionsfare ved fejlagtig håndtering.
Udskiftning må kun ske med batteri af samme fabrikat og type.
Lever det brugte batteri tilbage til leverandøren.

VARNING!

Explosionsfara vid felaktigt batteribyte.
Använd samma batterityp eller en ekvivalent typ som rekommenderas av apparattillverkaren.
Kassera använt batteri enligt fabrikantens instruktion.

ADVARSEL!

Lithiumbatteri – Eksplosjonsfare.
Ved utskifting benyttes kun batteri som anbefalt av apparatfabrikanten.
Brukt batteri returneres apparatleverandøren.

VAROITUS!

Paristo voi räjähtää, jos se on virheellisesti asennettu.
Vaihda paristo ainoastaan laitevalmistajan suosittelemaan tyyppiin. Hävitä käytetty paristo valmistajan ohjeiden mukaisesti.

For Germany

Bescheinigung des Herstellers/Importeurs

Hiermit wird bescheinigt, daß der/die/das

Roland 16 PART MULTI TIMBRAL SYNTHSIZER JV-30

(Gerät, Typ, Bezeichnung)

in Übereinstimmung mit den Bestimmungen der

Amtsbl. Vfg 1046/1984

(Amtsblattverfügung)

funk-entstört ist.

Der Deutschen Bundespost wurde das Inverkehrbringen dieses Gerätes angezeigt und die Berechtigung zur Überprüfung der Serie auf Einhaltung der Bestimmungen eingeräumt.

Roland Corporation Osaka/Japan

Name des Herstellers/Importeurs

For the USA

RADIO AND TELEVISION INTERFERENCE

WARNING — This equipment has been verified to comply with the limits for a Class B computing device, pursuant to Subpart J, of Part 15, of FCC rules. Operation with non-certified or non-verified equipment is likely to result in interference to radio and TV reception.

The equipment described in this manual generates and uses radio frequency energy. If it is not installed and used properly, that is, in strict accordance with our instructions, it may cause interference with radio and television reception. This equipment has been tested and found to comply with the limits for a Class B computing device in accordance with the specifications in Subpart J, of Part 15, of FCC Rules. These rules are designed to provide reasonable protection against such a interference in a residential installation. However, there is no guarantee that the interference will not occur in a particular installation. If this equipment does cause interference to radio or television reception, which can be determined by turning the equipment on and off, the user is encouraged to try to correct the interference by the following measure:

- Disconnect other devices and their input/output cables one at a time. If the interference stops, it is caused by either the other device or its I/O cable. These devices usually require Roland designated shielded I/O cables. For Roland devices, you can obtain the proper shielded cable from your dealer. For non Roland devices, contact the manufacturer or dealer for assistance.

If your equipment does cause interference to radio or television reception, you can try to correct the interference by using one or more of the following measures:

- Turn the TV or radio antenna until the interference stops.
- Move the equipment to one side or the other of the TV or radio.
- Move the equipment farther away from the TV or radio.
- Plug the equipment into an outlet that is on a different circuit than the TV or radio. (That is, make certain the equipment and the radio or television set are on circuits controlled by different circuit breakers or fuses.)
- Consider installing a rooftop television antenna with coaxial cable lead-in between the antenna and TV. If necessary, you should consult your dealer or an experienced radio/television technician for additional suggestions. You may find helpful the following booklet prepared by the Federal Communications Commission: "How to Identify and Resolve Radio — TV Interference Problems"

This booklet is available from the U.S. Government Printing Office, Washington, D.C., 20402, Stock No. 004-000-00345-4.

For Canada

CLASS B

NOTICE

This digital apparatus does not exceed the Class B limits for radio noise emissions set out in the Radio Interference Regulations of the Canadian Department of Communications.

CLASSE B

AVIS

Cet appareil numérique ne dépasse pas les limites de la classe B au niveau des émissions de bruits radioélectriques fixés dans le Règlement des signaux parasites par le ministère canadien des Communications.

